



1200 G Street, NW
Suite 500
Washington, DC 20005

P: +1 202-628-6380
W: www.atis.org

September 21, 2017

Via Email

Mary Boyd
Chair, CSRIC VI Working Group 1
Vice President, Regulatory Policy & External Affairs
West Safety Services
1601 Dry Creek Drive
Longmont, CO 80501

Re: *Comparison of Enhanced 9-1-1 (E9-1-1) and Next Generation 9-1-1 (NG9-1-1)
Focused on Reportable Outage Data Points (ATIS-0500034)*

Dear Ms. Boyd:

The Alliance for Telecommunications Industry Solutions (ATIS), on behalf of its Network Reliability Steering Committee (NRSC), is pleased to provide a copy of the ATIS technical report entitled *Comparison of Enhanced 9-1-1 (E9-1-1) and Next Generation 9-1-1 (NG9-1-1) Focused on Reportable Outage Data Points (ATIS-0500034)* for consideration by CSRIC VI Working Group 1.

This report describes the architectures to support emergency call handling in legacy Enhanced 9-1-1 (E9-1-1), as well as in transitional and end-state Next Generation 9-1-1 (NG9-1-1) environments, and compares the ability to detect failures/outages associated with emergency call and data delivery in the context of the legacy E9-1-1 and NG9-1-1 architectures. The report also compares the services architectures used today to provide E9-1-1 with NG9-1-1 services architectures and to identify where in the architectures service-impacting events can be detected. It should be noted, however, that the technical limitations outlined may limit any given stakeholder's monitoring and reporting capabilities.

This report provides information that CSRIC WG 1 may find useful as it carries out its mission. Subject matter experts from ATIS and its NRSC would be willing to participate in CSRIC meetings to serve as a resource or provide a primary walk-through of the document.

Letter to M. Boyd
September 21, 2017
Page 2

If you have any questions, would like additional information about this matter, or have any interest in collaborating on this effort, please contact me.

Sincerely,



Tom Goode
ATIS General Counsel

cc w/attachment:

Andis Kalnins, NRSC Co-Chair (Verizon), andis.i.kalnins@verizon.com
Andy Gormley, NRSC Co-Chair (T-Mobile), andy.gormley@t-mobile.com
John Healy, FCC Liaison for CSRIC VI WG 1, john.healy@fcc.gov
Timothy May, FCC Liaison for CSRIC VI WG 1, timothy.may@fcc.gov



ATIS-0500034

**Comparison of Enhanced 9-1-1 (E9-1-1) and Next
Generation 9-1-1 (NG9-1-1) Focused on Reportable
Outage Data Points**

TECHNICAL REPORT



As a leading technology and solutions development organization, the Alliance for Telecommunications Industry Solutions (ATIS) brings together the top global ICT companies to advance the industry's most pressing business priorities. ATIS' nearly 200 member companies are currently working to address the All-IP transition, 5G, network functions virtualization, big data analytics, cloud services, device solutions, emergency services, M2M, cyber security, network evolution, quality of service, billing support, operations, and much more. These priorities follow a fast-track development lifecycle — from design and innovation through standards, specifications, requirements, business use cases, software toolkits, open source solutions, and interoperability testing.

ATIS is accredited by the American National Standards Institute (ANSI). The organization is the North American Organizational Partner for the 3rd Generation Partnership Project (3GPP), a founding Partner of the oneM2M global initiative, a member of and major U.S. contributor to the International Telecommunication Union (ITU), as well as a member of the Inter-American Telecommunication Commission (CITEL). For more information, visit www.atis.org.

Notice of Disclaimer & Limitation of Liability

The information provided in this document is directed solely to professionals who have the appropriate degree of experience to understand and interpret its contents in accordance with generally accepted engineering or other professional standards and applicable regulations. No recommendation as to products or vendors is made or should be implied.

NO REPRESENTATION OR WARRANTY IS MADE THAT THE INFORMATION IS TECHNICALLY ACCURATE OR SUFFICIENT OR CONFORMS TO ANY STATUTE, GOVERNMENTAL RULE OR REGULATION, AND FURTHER, NO REPRESENTATION OR WARRANTY IS MADE OF MERCHANTABILITY OR FITNESS FOR ANY PARTICULAR PURPOSE OR AGAINST INFRINGEMENT OF INTELLECTUAL PROPERTY RIGHTS. ATIS SHALL NOT BE LIABLE, BEYOND THE AMOUNT OF ANY SUM RECEIVED IN PAYMENT BY ATIS FOR THIS DOCUMENT, AND IN NO EVENT SHALL ATIS BE LIABLE FOR LOST PROFITS OR OTHER INCIDENTAL OR CONSEQUENTIAL DAMAGES. ATIS EXPRESSLY ADVISES THAT ANY AND ALL USE OF OR RELIANCE UPON THE INFORMATION PROVIDED IN THIS DOCUMENT IS AT THE RISK OF THE USER.

NOTE - The user's attention is called to the possibility that compliance with this standard may require use of an invention covered by patent rights. By publication of this standard, no position is taken with respect to whether use of an invention covered by patent rights will be required, and if any such use is required no position is taken regarding the validity of this claim or any patent rights in connection therewith. Please refer to [<http://www.atis.org/legal/patentinfo.asp>] to determine if any statement has been filed by a patent holder indicating a willingness to grant a license either without compensation or on reasonable and non-discriminatory terms and conditions to applicants desiring to obtain a license.

ATIS-0500034, *Comparison of Enhanced 9-1-1 (E9-1-1) and Next Generation 9-1-1 (NG9-1-1) Focused on Reportable Outage Data Points*

Is an ATIS Standard developed by the **Next Generation Interconnection Interoperability Forum (NGES)** Subcommittee under the **ATIS Emergency Services Interconnection Forum (ESIF)**.

Published by

Alliance for Telecommunications Industry Solutions
1200 G Street, NW, Suite 500
Washington, DC 20005

Copyright © 2017 by Alliance for Telecommunications Industry Solutions
All rights reserved.

No part of this publication may be reproduced in any form, in an electronic retrieval system or otherwise, without the prior written permission of the publisher. For information contact ATIS at 202.628.6380. ATIS is online at < <http://www.atis.org> >.

ATIS Technical Report on

Comparison of Enhanced 9-1-1 (E9-1-1) and Next Generation 9-1-1 (NG9-1-1) Focused on Reportable Outage Data Points

Alliance for Telecommunications Industry Solutions

Approved June 7, 2017

Abstract

This Technical Report compares the ability to detect failures/outages associated with emergency calls in an Enhanced 9-1-1 (E9-1-1) environment versus a transitional and end-state NG9-1-1 environment.

Foreword

The Alliance for Telecommunications Industry Solutions (ATIS) serves the public through improved understanding between carriers, customers, and manufacturers.

The Emergency Services Interconnection Forum (ESIF) provides a forum to facilitate the identification and resolution of technical and/or operational issues related to the interconnection of wireline, wireless, cable, satellites, Internet, and emergency services networks.

The ESIF Next Generation Emergency Services (NGES) Subcommittee coordinates emergency services needs and issues with and among SDOs and industry forums/committees, within and outside ATIS, and develops emergency services (such as E9-1-1) standards, and other documentation related to advanced (i.e., Next Generation) emergency services architectures, functions, and interfaces for communications networks.

The mandatory requirements are designated by the word *shall* and recommendations by the word *should*. Where both a mandatory requirement and a recommendation are specified for the same criterion, the recommendation represents a goal currently identifiable as having distinct compatibility or performance advantages. The word *may* denotes an optional capability that could augment the standard. The standard is fully functional without the incorporation of this optional capability.

Suggestions for improvement of this document are welcome. They should be sent to the Alliance for Telecommunications Industry Solutions, ESIF, 1200 G Street NW, Suite 500, Washington, DC 20005.

At the time of consensus on this document, the committees responsible for its development had the following leadership:

- S. Sherwood, ESIF Chair (Verizon Wireless)
- R. Hixson, ESIF First Vice-Chair (NENA)
- R. Marshall, ESIF Second Vice-Chair (Comtech)
- C. Militeau, ESIF NGES Co-Chair (West Corporation)
- T. Reese, ESIF NGES Co-Chair (Ericsson)

The Next Generation Emergency Services (NGES) Subcommittee was responsible for the development of this document.

Table of Contents

1	Scope, Purpose, & Application	1
1.1	Scope.....	1
1.2	Purpose	1
1.3	Application	1
2	Informative References.....	1
3	Definitions, Acronyms, & Abbreviations	2
3.1	Definitions	2
3.2	Acronyms & Abbreviations.....	2
3.3	Descriptions of Stakeholder Roles.....	5
3.3.1	<i>Originating Service Provider (OSP) Using Legacy Technology</i>	5
3.3.2	<i>Originating Service Provider (OSP)-IP-Based Technology</i>	5
3.3.3	<i>Legacy Network Gateway (LNG) Operator</i>	5
3.3.4	<i>E9-1-1 System Service Provider (E911SSP)</i>	5
3.3.5	<i>Next Generation 9-1-1 System Service Provider (NG911SSP)</i>	6
3.3.6	<i>Legacy Public Safety Answering Point (PSAP) Gateway (LPG) Operator</i>	6
4	Legacy E9-1-1 Architecture Overview	6
4.1	Legacy Wireline E9-1-1 Service Architecture	7
4.2	Legacy Wireless E9-1-1 Service.....	8
4.2.1	<i>Wireline Compatibility Mode Approach</i>	9
4.2.2	<i>Wireless NCAS Approach</i>	9
4.2.3	<i>Handling of Interim VoIP Originations Using E9-1-1 Infrastructure</i>	10
5	NG9-1-1 Architecture Overview	11
5.1.1	<i>NG9-1-1 Service Architecture – All-IP End State</i>	12
5.1.2	<i>Transitional/Interworking Architectures in Support of Emergency Calling</i>	13
6	Detection of Failures in Emergency Call &/or Data Delivery	25
6.1	Legacy E9-1-1 Environment	25
6.1.1	<i>Functional Elements</i>	26
6.1.2	<i>Demarcation Points</i>	27
6.1.3	<i>Interfaces</i>	28
6.1.4	<i>Considerations for Redundant SRs (Dual Tandems)</i>	29
6.1.5	<i>E9-1-1 Failure Considerations</i>	29
6.1.6	<i>Current E9-1-1 Reporting Metrics</i>	32
6.2	NG9-1-1 Environment.....	32
6.2.1	<i>Functional Elements</i>	33
6.2.2	<i>Demarcation Points</i>	35
6.2.3	<i>NG9-1-1 Failure Considerations – All-IP End-State</i>	37
6.2.4	<i>Interworking Architecture Involving Legacy Network Gateway</i>	38
6.2.5	<i>Interworking Architecture Involving Legacy PSAP Gateway</i>	41
6.2.6	<i>Transitional Architecture Involving Legacy Selective Router Gateway</i>	43
7	Bandwidth Sizing in Support of NG9-1-1	50
8	Summary	51
A	Roles-to-Failure Visibility Chart	52

Table of Figures

Figure 4.1 – E9-1-1 Architecture for Wireline Emergency Calls	8
Figure 4.2 – Wireless E9-1-1 – Wireline Compatibility Mode.....	9
Figure 4.3 – Wireless E9-1-1 – NCAS Approach.....	10
Figure 4.4 – VoIP Originations to E9-1-1	11
Figure 5.1 – NG9-1-1 Service Architecture (All-IP End State).....	12
Figure 5.2 – NG9-1-1 Service Architecture Involving Legacy Network Gateway.....	15
Figure 5.3 – NG9-1-1 Service Architecture Involving Legacy PSAP Gateway	18
Figure 5.4 – NG9-1-1 Service Architecture Involving Ingress Legacy Selective Router Gateway.....	20
Figure 5.5 – NG9-1-1 Service Architecture Involving Egress Legacy Selective Router Gateway	24
Figure 6.1 – Typical E9-1-1 Environment	26
Figure 6.2 – Redundant SRs (Dual Tandems).....	29
Figure 6.3 – NG9-1-1 Environment.....	33
Figure 6.4 – Transitional Architecture with Ingress Legacy Selective Router Gateway.....	43
Figure 6.5 – Transitional Architecture with Egress Legacy Selective Router Gateway	47

Comparison of Enhanced 9-1-1 (E9-1-1) and Next Generation 9-1-1 (NG9-1-1) Focused on Reportable Outage Data Points

1 Scope, Purpose, & Application

1.1 Scope

This Technical Report describes the architectures to support emergency call handling in legacy Enhanced 9-1-1 (E9-1-1), as well as in transitional and end-state Next Generation 9-1-1 (NG9-1-1) environments, and compares the ability to detect failures/outages associated with emergency call and data delivery in the context of the legacy E9-1-1 and NG9-1-1 architectures.

1.2 Purpose

As telecommunications networks continue to evolve to all-IP, the FCC has begun investigating the possible expansion of its Part 4 Outage Reporting rules to include broadband and performance metrics (e.g., throughput, latency, and packet loss) in the FNPRM PS Docket No. 11-82 (FCC 16-63) [Ref 4].

As a result, there is a need for service providers across all industry segments (cable, wireline, and wireless), in all stages of the PSTN transition, to be able to identify when their networks may be experiencing service-impacting events that impair or cause the total loss of 9-1-1 services. As service architectures to support 9-1-1 calling and data delivery evolve to NG9-1-1, there is a need to better understand the complexities of how NG9-1-1 service architectures are designed and where there are divergences from the pre-existing legacy E9-1-1 network infrastructures. This information will be critical for service providers to know so as to a) collect network information that may be reportable under the Part 4 Rules and b) to evaluate if standardization efforts are needed to develop metrics for data collection.

The purpose of this Technical Report is to compare the services architectures used today to provide E9-1-1 with NG9-1-1 service architectures and to identify where in the architectures service-impacting events can be detected. However, it should be noted that the technical limitations outlined in this document limit any given stakeholder's monitoring and reporting capabilities.

1.3 Application

This Technical Report applies to emergency call handling and data delivery via legacy and Next Generation (NG) emergency services architectures defined in North American standards in support of regulatory activities associated with 9-1-1-related outage reporting applicable to the U.S. This Technical Report is applicable to wireline, wireless, and IP-based originating network providers as well as E9-1-1/NG9-1-1 System Service Providers.

2 Informative References

The following standards contain provisions which, through reference in this text, constitute provisions of this Standard. At the time of publication, the editions indicated were valid. All standards are subject to revision, and parties to agreements based on this Standard are encouraged to investigate the possibility of applying the most recent editions of the standards indicated below.

[Ref 1] NENA-INF-003.1-2013, *NENA Potential Points of Demarcation in NG9-1-1*, March 1, 2013.

[Ref 2] FCC 15-9, PS Docket No. 07-114, 4th Report and Order, *Fourth Report and Order In the Matter of Wireless E911 Location Accuracy Requirements*.

- [Ref 3] NENA-STA-010.2, *Detailed Functional and Interface Standards for the NENA i3 Solution*, September 10, 2016.
- [Ref 4] FCC 16-63, FNPRM PS Docket No. 11-82, *Report and Order, Further Notice of Proposed Rulemaking, and Order on Reconsideration*.
- [Ref 5] NENA-ADM-000.19-2016, *NENA Master Glossary of 9-1-1 Terminology*, December 20, 2016.
- [Ref 6] J-STD-034, *Wireless Enhances Emergency Services*, December 1997.
- [Ref 7] J-STD-036-C, *Enhanced Wireless 9-1-1 Phase II*, June 2011 including the addendum in J-STD-036-C-1, *Addendum to J-STD-036-C, Enhanced Wireless 9-1-1 Phase II*, October 2013.
- [Ref 8] NENA 05-001, *NENA Standard for the Implementation of the Wireless Emergency Service Protocol E2 Interface*, December 2, 2003.
- [Ref 9] OMA-TS-MLP-V3_2-20051124-C, *Mobile Location Protocol 3.2*, November 24, 2005.
- [Ref 10] NENA 03-506, *E9-1-1 Voice Circuit Requirements - Providing a P.01 Grade of Service*, April 13, 2007.
- [Ref 11] NENA 08-506, *Emergency Services IP Network Design for NG9-1-1*, December 14, 2011.

3 Definitions, Acronyms, & Abbreviations

For a list of common communications terms and definitions, please visit the *ATIS Telecom Glossary*, which is located at: < <http://www.atis.org/glossary> >.

3.1 Definitions

The use of these terms in this document is exclusively for the function of monitoring and reporting.

Demarcation Point: A mutually-defined boundary dividing one area of responsibility from another.

Physical Demarcation: A mutually-defined boundary dividing one area of responsibility for managing tangible assets, such as computers, routing hardware, or transmission lines from another.

Location Key: A location key may be the callback number and/or pseudo ANI (pANI) (ESRK, ESRD, or ESQK) that may be used for routing and acquiring caller location.

Logical Demarcation: A mutually-defined boundary dividing one area of responsibility for managing NG9-1-1 functional elements from another. The interfaces for these functional elements include the interfaces for intangible assets, such as data stores and applications.

3.2 Acronyms & Abbreviations

ADR	Additional Data Repository
AGPS	Assisted Global Positioning System
ALI	Automatic Location Identification
ANI	Automatic Number Identification
AOA	Angle of Arrival
ATIS	Alliance for Telecommunications Industry Solutions
BCF	Border Control Function
CAMA	Centralized Automatic Message Accounting

ATIS-0500034

CPE	Customer Premises Equipment
ECRF	Emergency Call Routing Function
ELT	English Language Translation
E-MF	Enhanced Multi-Frequency
EMS	Emergency Medical Services
ESGW	Emergency Services Gateway
ESN	Emergency Services Number
ESRP	Emergency Services Routing Proxy
ESZ	Emergency Services Zone
ESQK	Emergency Services Query Key
ESRD	Emergency Services Routing Digits
ESRK	Emergency Services Routing Key
E9-1-1	Enhanced 9-1-1
E911SSP	Enhanced 9-1-1 System Service Provider
FCC	Federal Communications Commission
FGD	Feature Group D
FNPRM	Further Notice of Proposed Rule Making
GMLC	Global Mobile Location Center
GOS	Grade Of Service
IAM	Initial Address Message
ILEC	Incumbent Local Exchange Carrier
IMS	IP Multimedia Subsystem
IP	Internet Protocol
ISDN	Integrated Services Digital Network
ISUP	ISDN User Part
LIS	Location Information Server
LNG	Legacy Network Gateway
LoST	Location to Service Translation
LPG	Legacy PSAP Gateway
LRF	Location Routing Function
LS	Location Server
LSRG	Legacy Selective Router Gateway
MDN	Mobile Directory Number

ATIS-0500034

MF	Multi-Frequency
MGCF	Media Gateway Control Function
MGW	Media Gateway
MLP	Mobile Location Protocol
MPC	Mobile Positioning Center
MSC	Mobile Services Switching Center
NANP	North American Numbering Plan
NCAS	Non-Call Associated Signaling
NENA	National Emergency Number Association
NG	Next Generation
NG9-1-1	Next Generation 9-1-1
NG911SSP	Next Generation 9-1-1 System Service Provider
NPA	Numbering Plan Area
NPD	Number Planning Digit
OSP	Originating Service Provider
PAM	PSAP to ALI Messaging
pANI	pseudo Automatic Number Identification
PIDF-LO	Presence Information Data Format – Location Object
PSAP	Public Safety Answering Point
PSTN	Public Switched Telephone Network
SIP	Session Initiation Protocol
SR	Selective Router
SRDB	Selective Routing Database
SS7	Signaling System 7
SSP	System Service Provider
TDOA	Time Difference of Arrival
URI	Uniform Resource Identifier
URN	Uniform Resource Name
VPC	VoIP Positioning Center
VPN	Virtual Private Network
VoIP	Voice over Internet Protocol
WCM	Wireline Compatibility Mode
WSP	Wireless Service Provider

3.3 Descriptions of Stakeholder Roles

These Stakeholder Role descriptions provide a common understanding of how the terms are used within this document. The rationale is that not everyone will know what any of these roles do and do not do. These Stakeholder Roles may be implementation- and business model-specific.

It is also important to point out that sometimes any single company/entity might serve in multiple roles, e.g., an Incumbent Local Exchange Carrier (ILEC) could be serving as an Originating Service Provider (OSP) (legacy or IP-based), a Legacy Network Gateway (LNG) operator, an NG9-1-1 System Service Provider (NG911SSP), a Legacy PSAP Gateway (LPG) Operator, and Location Retrieval Function (LRF) Operator, or any combination of those. A government entity (9-1-1 Authority) could serve in any of these roles.

To the extent possible, the following descriptions are based on the National Emergency Number Association (NENA) Master Glossary of 9-1-1 Terminology [Ref 5].

3.3.1 Originating Service Provider (OSP) Using Legacy Technology

A legacy-based OSP role provides the ability for a caller to make calls. In the context of this document, it is focused on the ability to make 9-1-1 calls. It is the OSP's responsibility to forward 9-1-1 calls toward the serving emergency services network. Since the legacy-based OSP is using non-IP technology, calls destined for an NG emergency services network must go through a gateway.

The OSP-Legacy role may be provided by traditional "phone companies", competitive "phone companies", or other private or public communications entities that are not using IP-based technology.

3.3.2 Originating Service Provider (OSP)-IP-Based Technology

An IP-based OSP role provides the ability for a caller to make calls using Internet Protocol (IP) signaling. In the context of this document, it is focused on the ability to make IP-based 9-1-1 calls. It is the OSP's responsibility to forward 9-1-1 calls toward the serving emergency services network. Since the IP-based OSP is using IP technology, calls destined for an NG emergency services network are not required to go through a gateway.

The OSP-IP role may be provided by traditional "phone companies", competitive "phone companies", or other private or public communications entities that are using IP-based technology.

3.3.3 Legacy Network Gateway (LNG) Operator

The LNG is an NG9-1-1 Functional Element that provides an interface between a non-IP originating network and an NG emergency services network. In this document, the entity that provides the LNG is referred to as the LNG operator. That would typically be the NG911SSP or the OSP-Legacy. It could also be a government entity or a third party.

3.3.4 E9-1-1 System Service Provider (E911SSP)

An E911SSP provides systems and support necessary to enable 9-1-1 calling for one or more Public Safety Answering Points (PSAPs) in a specific geographic area. It is typically, but not always, an ILEC.

The E911SSP role includes providing:

- A method of interconnection for all telecommunications providers, including but not limited to wireline, wireless, and VoIP carriers.
- A method and mechanism for routing a 9-1-1 call to the Public Safety Answering Point (PSAP) with no degradation in service regardless of the technology used to originate the call.
- A method to provide accurate location information for an emergency caller to a PSAP and, if required, to other emergency response agencies.
- Installation of PSAP call handling equipment and training of PSAP personnel when contracted to do so.
- Coordinating with PSAP authorities and other telecommunications entities for troubleshooting and on issues involving contingency planning, disaster mitigation, and recovery.

- Support for Legacy Selective Router Gateway (LSRG) functionality to facilitate the interconnection of legacy Selective Routers with NG emergency services networks.

3.3.5 Next Generation 9-1-1 System Service Provider (NG911SSP)

An NG911SSP provides systems and support necessary to enable 9-1-1 calling for one or more PSAPs in a specific geographic area. In the past (in E9-1-1) it was typically, but not always, an ILEC. In NG9-1-1, the role is more open to competition, and there are NG emergency services networks in use that are provided by various entities, some of whom specialize in the NG911SSP role.

The NG911SSP role includes providing:

- A method of interconnection for all telecommunications providers, including but not limited to wireline, wireless, and VoIP carriers.
- A method and mechanism for routing a 9-1-1 call to the Public Safety Answering Point (PSAP) with no degradation in service regardless of the technology used to originate the call.
- A method to provide accurate location information for an emergency caller to a PSAP and, if required, to other emergency response agencies.
- Installation of PSAP call handling equipment and training of PSAP personnel when contracted to do so.
- Coordinating with PSAP authorities and other telecommunications entities for troubleshooting and on issues involving contingency planning, disaster mitigation, and recovery.

3.3.6 Legacy Public Safety Answering Point (PSAP) Gateway (LPG) Operator

The LPG is an NG9-1-1 Functional Element that provides an interface between an NG emergency services network and a legacy PSAP.

In this document, the entity that provides the LPG is referred to as the LPG operator. That would typically be the NG911SSP or the 9-1-1 Authority/PSAP, but it could be a third party.

4 Legacy E9-1-1 Architecture Overview

Enhanced 9-1-1 (E9-1-1) Service is a public safety feature that allows emergency calls to be routed to a designated Emergency Service bureau when the 3-digit telephone number “9-1-1” is dialed. The Emergency Service bureau is a centralized agency or facility that a municipality operates to receive and respond to requests for emergency services such as police, fire, and Emergency Medical Services (EMS). Attendants at the Emergency Service bureau may be personnel from the police or fire department, or any agency designated to receive emergency calls. In general, the centralized answering point for emergency calls is referred to as a Public Safety Answering Point (PSAP).

Existing E9-1-1 Service architectures, and any evolution to the service architecture brought about by changes in technology and the regulatory environment, must support critical functionality to facilitate the delivery of emergency services to those in need.

Selective Routers (SRs) (also known as E9-1-1 Tandems) are a critical element of legacy Emergency Services Networks that support E9-1-1 Service. SRs are specially-equipped central offices that provide the switching of 9-1-1 calls. Selective routing is the process by which 9-1-1 calls are routed to the appropriate PSAP (or other designated destination) based on the caller’s location. For emergency calls that originate in legacy wireline networks, the caller’s location is represented by their 10-digit telephone number or Automatic Number Identification (ANI). For emergency calls that originate in legacy wireless networks, selective routing is done based on a 10-digit location key that represents the cell site and sector that the caller is calling from. In addition to providing selective routing functionality, SRs control the delivery of voice calls to the PSAP, as well as emergency call transfer and certain maintenance functions for each PSAP.

Today, SRs typically receive emergency calls over dedicated Multi-Frequency (MF) or Signaling System No. 7 (SS7) trunk groups from wireline end offices and Mobile Switching Centers (MSCs). They use information received in incoming signaling to identify the PSAP that serves the area in which the call originated. SRs deliver the emergency call to the PSAP, typically over traditional Centralized Automatic Message Accounting (CAMA)-like or

ATIS-0500034

Enhanced MF interfaces, with a location key that allows the PSAP to query an Automatic Location Identification (ALI) database for the caller's location information. Having retrieved the location information, the PSAP can facilitate the dispatch of emergency personnel to the incident location.

At a high level, the primary capabilities of E9-1-1 Service consist of the following:

- Emergency calls are detected based on the dialed digits "9-1-1"
- Emergency calls are selectively routed via an SR/ switch to an appropriate serving PSAP, based on the caller's location (or approximate location). Note that in some abnormal cases, default routing may apply; alternate routing may also be invoked under certain circumstances
- A callback number is delivered to the PSAP with the call (although there are some exceptions for certain wireless implementations and non-initialized handsets)
- The PSAP uses information received in call setup signaling to query the ALI database to obtain location information for the caller
- The PSAP call-taker may transfer the call to another agency for further handling (e.g., for dispatch).

As described above, a unique feature of E9-1-1 is selective routing. Selective Routing allows 9-1-1 calls to be routed to the appropriate PSAP based on the calling number/ANI, or other location information that may be provided with the call. To support selective routing, an SR will interact with a Selective Routing Database (SRDB). The SR provides the calling number/ANI or location key to the SRDB, and the SRDB returns an Emergency Service Number (ESN). An ESN is a three- to five-digit number representing a unique combination of emergency service agencies (law enforcement, fire, and EMS) designated to serve a specific range of addresses within a particular geographical area referred to as an Emergency Service Zone (ESZ). The SR uses the ESN to select the path to the destination PSAP for the emergency call. The ESN may also play a role in selecting the transfer-to PSAP if the primary PSAP requests selective transfer of the emergency call, and identifying English Language Translations (ELTs) that specify the corresponding police, fire, and EMS.

The introduction of the ANI feature was critical to supporting E9-1-1 because it allowed delivery of the 9-1-1 caller's telephone number¹ to the PSAP with the call. Using this information, the PSAP could identify the caller and, if necessary, call back the caller. A CAMA-like MF signaling scheme was initially used to support ANI delivery to the PSAP. This signaling scheme, referred to as Traditional MF, is still in use in certain areas today, and supports the delivery of a 7-digit number, along with a single Numbering Plan Digit (NPD) that can be used to derive the NPA and to indicate whether the ANI information should be displayed using a steady or flashing display. A flashing display is intended to alert the Telecommunicator of special conditions related to call treatment. A Feature Group D-like signaling scheme, referred to as Enhanced MF (E-MF), is more commonly used between SRs and PSAPs, and supports the delivery of either one or two 10-digit numbers to the PSAP with the call, along with an ANI II value that tells the PSAP Customer Premise Equipment (CPE) whether to display the information using a steady or flashing display.

4.1 Legacy Wireline E9-1-1 Service Architecture

The delivery of the wireline 9-1-1 caller's telephone number allows PSAPs to access the location information associated with the telephone number by querying the ALI database. In the case of wireline emergency callers, the ALI database contains static telephone number-to-street address mappings. The carrier that serves the PSAP typically operates the ALI databases.

Figure 4.1 shows a representative architecture for wireline E9-1-1.

¹ Technically, the ANI is the billing number associated with the calling party; however, in most cases, the ANI is the same as the calling directory number.

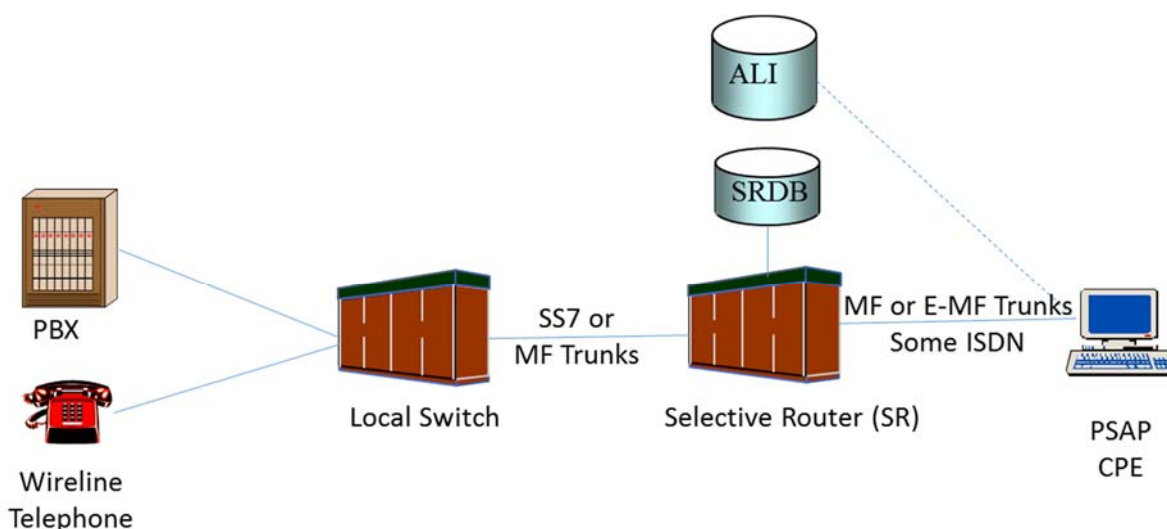

Figure 4.1 – E9-1-1 Architecture for Wireline Emergency Calls

4.2 Legacy Wireless E9-1-1 Service

Enhanced wireless emergency services (i.e., wireless E9-1-1), requiring wireless carriers to provide the location of the wireless 9-1-1 callers to PSAPs, is mandated by the U.S. Federal Communications Commission (FCC). For the initial stage, Phase I, the FCC required Wireless Service Providers (WSPs) to upgrade their networks to support delivery of a callback number, and an identifier of the cell site or base station location where the 9-1-1 call originated, to the PSAP. Phase I of the FCC's mandate was required to be implemented by April 1998.

Phase II requires delivery of E9-1-1 service that includes the latitude and longitude of the 9-1-1 call within specific accuracy and reliability parameters, depending on the location technology that the carriers have chosen. For network-based technologies, location must be accurate to within 100 meters for 67 percent of calls, and 300 meters for 90 percent of calls. For handset-based technologies, location must be accurate to within 50 meters for 67 percent of calls, and 150 meters for 90 percent of calls. While the original order called for handset-based geographic location to be provided to the PSAPs by October 1, 2001, the FCC has since introduced a phased-in implementation schedule for handset and network-based location that extends until January 2019.

The industry standard for E9-1-1 Phase I, J-STD-034, uses the term Emergency Services Routing Digits (ESRD) for the cell site identifier that is associated with an emergency call. With E9-1-1 Phase I, the SR uses the ESRD to selectively route the wireless 9-1-1 call to the appropriate PSAP. Specifically, the SR queries the SRDB using the ESRD. As in the wireline architecture described above, the SR receives an ESN in the response from the SRDB and associates the ESN with the destination PSAP. The PSAP uses this ESRD to query for callback number and cell site location information.

To satisfy the FCC Phase I mandate, the MSC may provide emergency call-related information to the SR using SS7 or Feature Group D (FGD) signaling. The interface between the SR and the PSAP may support (depending on PSAP capabilities) the delivery of the two 10-digit numbers (i.e., callback number and ESRD) provided by the MSC to the PSAP using the E-MF signaling interface defined by NENA. However, there are still PSAPs that support Traditional MF interfaces and a small percentage of PSAPs that support a custom Integrated Services Digital Network (ISDN) interface that is also capable of delivering 20 digits from the wireless carriers.

To fulfill Phase II requirements for the delivery of latitude and longitude associated with the 9-1-1 call, wireless carriers have had to deploy location determination technology in their networks. The location technology may be handset-based (e.g., Assisted Global Positioning System [AGPS]) or network-based (e.g., Time Difference of Arrival [TDOA], Angle of Arrival [AOA], etc.). Technically, if SS7 ISDN User Part (ISUP) signaling is supported between the MSC and the SR, Phase II location information could be delivered in the ISUP Initial Address Message (IAM), provided the wireless network is able to determine the location coordinates prior to call setup. However, due to limitations in today's location determination technology that result in delays in obtaining Phase II location, existing Phase II implementations only support the delivery of Phase I information or a location key in the call setup signaling. Phase II location information is delivered over a separate data link between the wireless network and the emergency services network. The E2 protocol defined in J-STD-036-C and NENA-05-001 is typically used over the data link

between the wireless network and emergency services network to request/deliver transport initial caller location information to the PSAP via the ALI system, and to provide updated location information when requested. There are also some implementations that use the Mobile Location Protocol (MLP) between the ALI system and the Mobile Positioning Center/MPC/Gateway Mobile Location Center (GMLC) in the wireless network to obtain the location associated with an emergency call.

The method in which Phase II location is delivered by the wireless network to the emergency services network via a separate data link is referred to as the Non-Call Associated Signaling (NCAS) approach in J-STD-036-C. There are two variants of this approach: one which is just referred to as NCAS, and the other which is referred to as Wireline Compatibility Mode (WCM). Of the two variants, the WCM approach is more widely deployed.

4.2.1 Wireline Compatibility Mode Approach

With the WCM approach, all the FCC-mandated Phase I and Phase II location information and the callback number are sent over a separate data link to the ALI database from the wireless network. The MSC may support either an MF or an SS7 interface over which a single 10-digit number is delivered to the SR, and the SR supports an interface where only a single 7/10-digit number is delivered to the PSAP. The one piece of information sent by the MSC to the SR is referred to as the Emergency Services Routing Key (ESRK). The ESRK may represent the PSAP or an ESZ in the jurisdiction of a PSAP, and also uniquely identifies the 9-1-1 call. The ESRK also uniquely identifies an MPC/GMLC in the wireless network that the ALI must query. The MPC/GMLC stores a pool of ESRKs in its database that represent a PSAP or ESZ and assigns them to wireless 9-1-1 calls. Upon completion of the 9-1-1 calls, the ESRKs are released, after the expiration of a guard timer, to be assigned to other 9-1-1 calls. The PSAP receives only the ESRK from the SR and uses it to query the ALI database to receive the callback number, cell site identifier (ESRD), and the latitude and longitude information for the mobile caller.

Figure 4.2 illustrates wireless emergency call handling using the WCM approach.

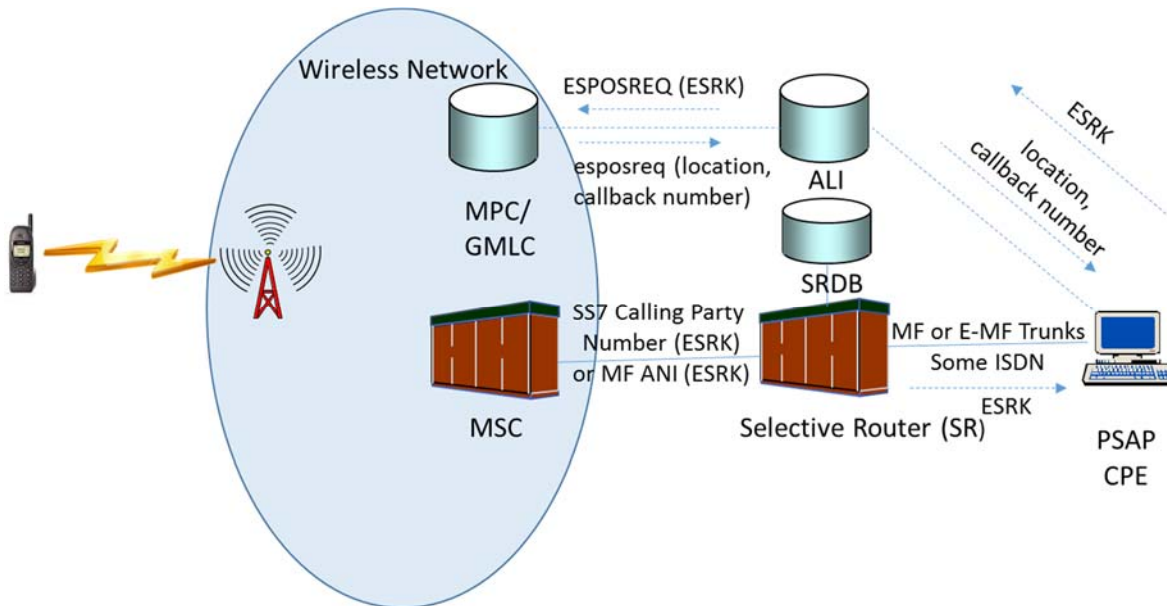

Figure 4.2 – Wireless E9-1-1 – Wireline Compatibility Mode

4.2.2 Wireless NCAS Approach

With the wireless NCAS approach, the MSC sends a callback number and the cell site identifier (ESRD) to the SR using either MF or SS7 signaling. Call setup using the wireless NCAS approach is identical to the call setup in the E9-1-1 Phase I scenario documented in J-STD-034. The SR uses the ESRD to interact with the SRDB, and the SRDB returns an ESN that causes the SR to route the 9-1-1 call to the appropriate PSAP. The interface between the SR and the PSAP will typically be an E-MF interface that supports the delivery of both the callback number and the ESRD to the PSAP, although hybrid arrangements (involving the real-time update of the ALI data via the SR)

may be used if the PSAP supports either a Traditional MF interface or the delivery of a single 10-digit number via an E-MF interface. Figure 4.3 illustrates wireless emergency call handling using the NCAS approach.

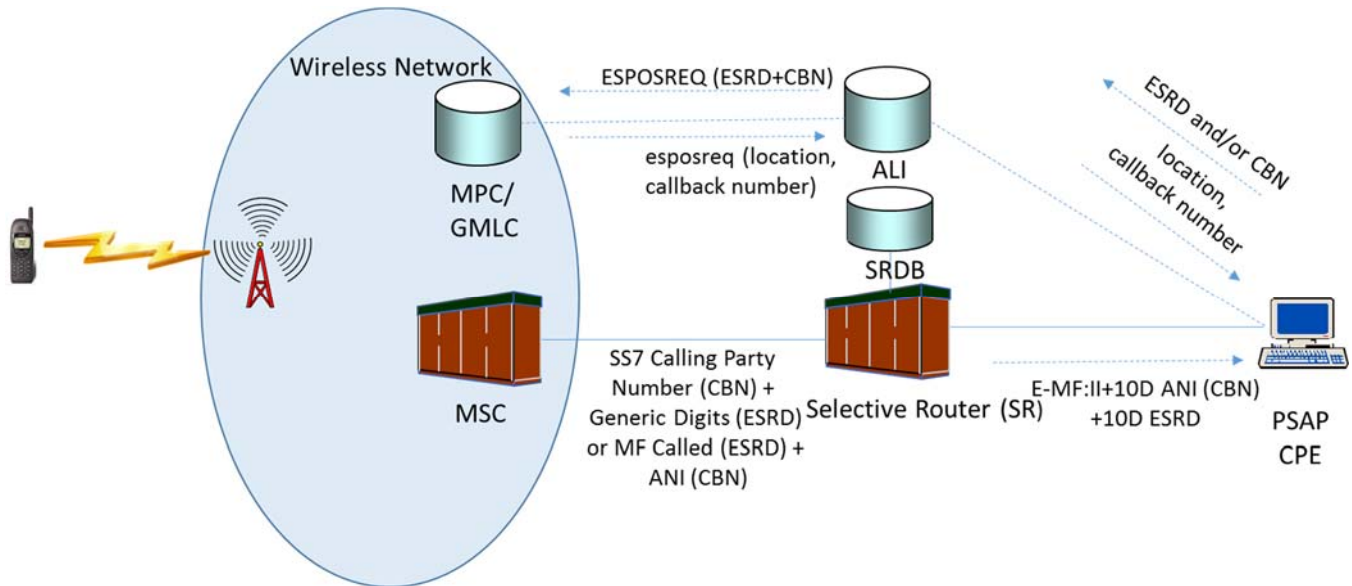

Figure 4.3 – Wireless E9-1-1 – NCAS Approach

4.2.3 Handling of Interim VoIP Originations Using E9-1-1 Infrastructure

Existing interim VoIP implementations use the wireless E9-1-1 WCM techniques described above as a basis for delivering emergency originations from VoIP callers to legacy PSAPs that are served by SRs, as shown in Figure 4.4 –. To support emergency calling, VoIP customers' location is managed by the VoIP provider. This location information is provisioned to a system referred to as a VoIP Positioning Center (VPC). When a 9-1-1 call is initiated, the VPC allocates an Emergency Services Query Key (ESQK) to the call (in a manner similar to the way that an MPC/GMLC allocates an ESRK to a wireless emergency call). The ESQK identifies a call instance at a VPC, and is associated with a particular SR/ESN combination. The ESQK is delivered to the SR (without a callback number) via an Emergency Services Gateway (ESGW) over an MF or SS7 interface. The SR then queries the SRDB using the ESQK to determine the route (i.e., trunk group) to the target PSAP. The SR delivers the ESQK to the PSAP via MF signaling. The PSAP uses the ESQK to query the ALI system, and the ALI system steers the query back to the VPC (in the same manner as it would steer a query to an MPC/GMLC for a wireless emergency call). The VPC responds with the provisioned location information and a callback number. The ALI system then passes the location and callback information to the PSAP.

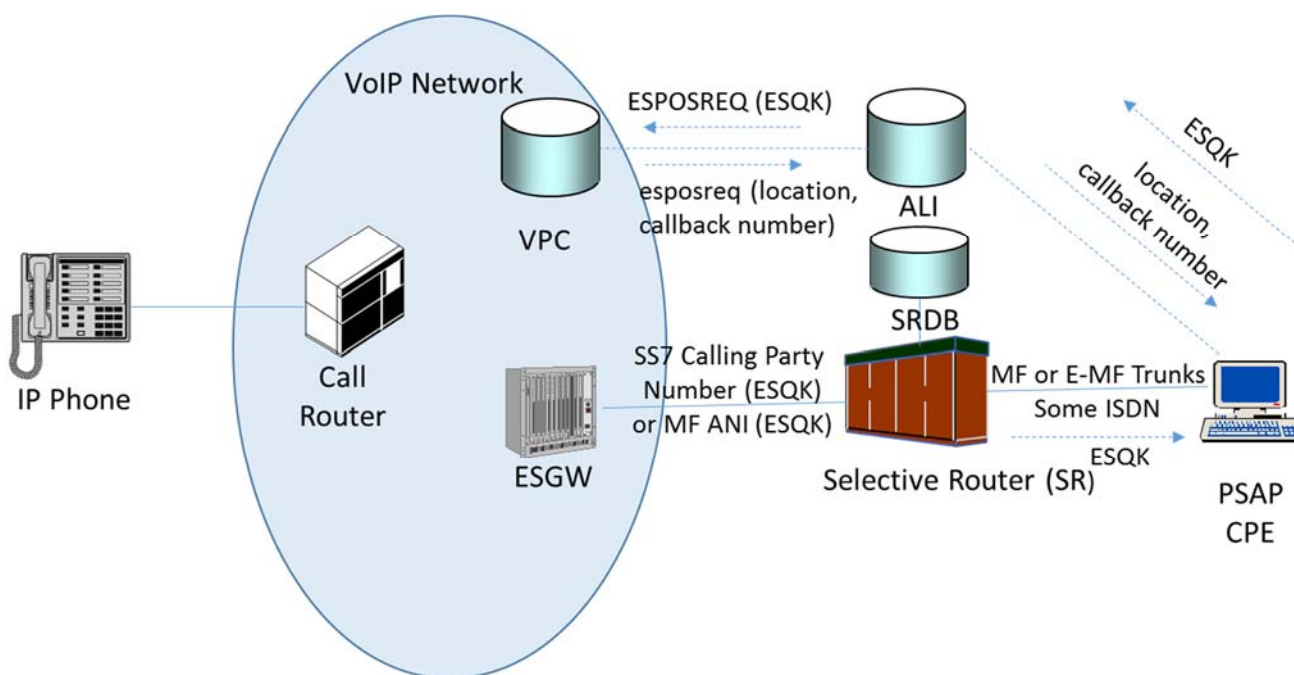

Figure 4.4 – VoIP Originations to E9-1-1

5 NG9-1-1 Architecture Overview

The goal of Next Generation 9-1-1 (NG9-1-1) is to provide at least E9-1-1-equivalent functionality in support of emergency call originations from fixed, nomadic, and mobile IP users, and to build on those capabilities to improve performance and extend feature functionality (e.g., to support delivery of text-based emergency services requests to PSAPs). There are a number of alternative NG9-1-1 Service architectures under discussion in various industry groups. NENA has defined a long term solution for emergency calling, referred to as the i3 Solution, whose end state assumes end-to-end IP signaling from an IP-enabled endpoint to an IP-enabled PSAP, with callback and caller location information provided to the PSAP with the call. Similarly, a joint work group in ATIS is defining the architecture, protocol, and procedures to support the processing of emergency calls by an IP Multimedia Subsystem (IMS)-based NG Emergency Services Network. Regardless of the Functional Elements and interfaces that make up these architectures, NG9-1-1 Service architectures must, at a minimum, support the E9-1-1 capabilities identified in Clause 4.

A fundamental capability required of any NG Emergency Services network is the ability to selectively route an emergency call to the appropriate PSAP based on the location from which the call was originated. This implies that information identifying the location of the caller must be available at any routing element in the call path. Emergency call setup in an NG9-1-1 environment is expected to be Session Initiation Protocol (SIP)-based. The SIP signaling associated with an emergency session request is expected to include location information, either “by value” (i.e., as a Presence Information Data Format – Location Object [PIDF-LO]) in the body of the SIP message or “by reference” (where a location reference is included in the SIP signaling and can be dereferenced to obtain the location value/PIDF-LO). The routing element is expected to use a location value to query a call routing function to obtain routing information for the call. The location information used as input to the call routing function can either be in the form of a civic/street address or geo-coordinates. The output of the call routing function is expected to be in the form of a Uniform Resource Identifier (URI).

If location-based routing cannot be performed because sufficient information is not received with the call to allow the location-based process to be successful (e.g., location information is not received with the call, or a route cannot be determined for the location value associated with the call), the NG Emergency Services Network must be able to route the call using a default location or default next hop URI (as appropriate for the abnormal condition encountered). Alternate/Overflow routing allows the NG Emergency Services Network to temporarily redirect emergency calls to/toward a pre-designated alternate PSAP/destination (e.g., a call center) when the primary PSAP or next hop element is not available to take calls (e.g., due to network/PSAP conditions or other policy).

When the NG Emergency Services Network delivers an emergency call to an NG PSAP, it is expected to generate SIP signaling that includes location information (by-value or by-reference), callback information, and Additional Data (by-value and/or by-reference). The location information that the NG Emergency Service Network signals to an NG PSAP will be the same as the location information that it received in incoming SIP signaling. For example, if a routing element within the NG Emergency Services Network receives location-by-reference in a SIP INVITE message associated with an incoming emergency call, and it dereferences that location reference to obtain a location-by-value with which to query a location-based routing functional element, it will still send the location-by-reference forward in outgoing SIP signaling to/toward the NG PSAP.

Likewise, routing elements in the NG Emergency Services Network may receive Additional Data associated with a call by reference and/or by value in an incoming SIP INVITE message associated with an emergency call. The routing element is expected to pass the Additional Data to/toward the NG PSAP in the same form as it was received. Today, PSAPs receive non-location information, such as class of service information, associated with an emergency call, in the response from the ALI system. PSAPs that receive emergency calls from the NG Emergency Services Network must, at a minimum, have the same type of non-location information available to them as is available in ALI responses today.

5.1.1 NG9-1-1 Service Architecture – All-IP End State

Figure 6.1 provides a high-level architecture diagram illustrating an end-state (i.e., all-IP) NG9-1-1 service architecture and how emergency calls are processed using this architecture.

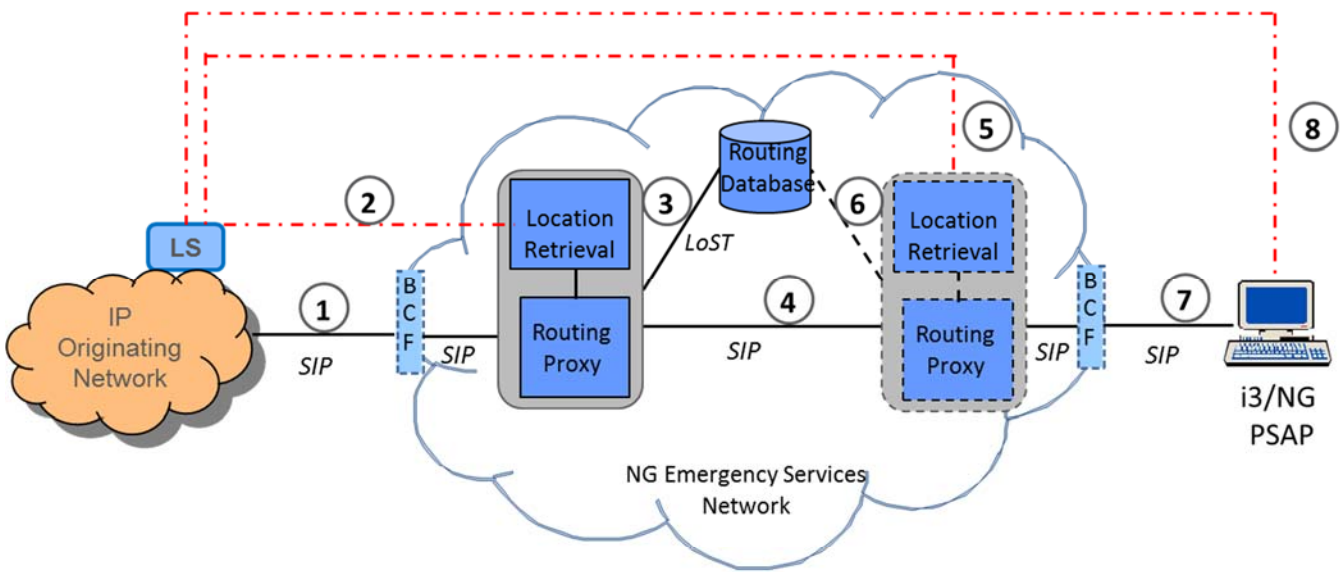

- BCF – Border Control Function
- IP – Internet Protocol
- LoST – Location to Service Translation
- LS – Location Server
- NG – Next Generation
- PSAP – Public Safety Answering Point
- SIP – Session Initiation Protocol

Figure 5.1 – NG9-1-1 Service Architecture (All-IP End State)

1. The emergency call/session request is delivered by the IP originating network (via a Border Control Function) to a routing proxy in the NG Emergency Services Network with callback information and location information.
 - Location may be delivered “by-value” (i.e., the civic location/street address or geo-coordinate location is contained within the SIP signaling message).

ATIS-0500034

- Location may be delivered “by-reference” (i.e., the SIP signaling message contains a “pointer” or “reference” to the location information that includes the address of the element from which the location information can be obtained and a “key” to the data).
2. If the location information is received “by-reference”, the location retrieval functionality within or accessible to the routing proxy will be invoked.
 - A dereference request will be sent to the element identified in the location reference (i.e., the Location Server [LS]) to obtain a routing location for the call.
 - If location is received “by-value”, this step will be omitted.
3. The routing proxy uses the location information received in incoming SIP signaling (location-by-value) or obtained by dereferencing a location-by-reference to query a routing database.
 - The routing database is queried using the Location to Service Translation (LoST) protocol.
 - The LoST routing query contains location information and an appropriate service identifier (i.e., a service Uniform Resource Name [URN] in the “sos” family).
 - The routing response contains the address of the “next hop” in call path, in the form of a Uniform Resource Identifier (URI).
4. The routing proxy forwards the emergency call/session request (with the **same** callback and location information as it received in incoming SIP signaling) to the “next hop” element based on the URI received in the LoST response.
 - The “next hop” element may be the PSAP or it may be another routing proxy in the call path, depending on the way the NG9-1-1 Service Architecture is implemented.
5. If the next hop in the call path is another routing proxy, and the location information was received in incoming SIP signaling “by-reference”, the routing proxy will invoke location retrieval functionality within or accessible to it to retrieve a routing location for the call.
 - A dereference request will be sent to the same element (LS) that the first routing proxy queried to get a routing location.
 - If location is received “by-value”, this step will be omitted.
6. If present in the call path, the routing proxy will use the location information received in incoming SIP signaling (location-by-value) or obtained by dereferencing a location-by-reference, and a service URN, to query a routing database using the LoST protocol.
7. The routing proxy forwards the emergency call/session request (with the **same** callback and location information as it received in incoming SIP signaling) to the “next hop” element based on the URI received in the LoST response.
 - In this example, the “next hop” is assumed to be the target PSAP for the emergency call.
 - In this example, the target PSAP is assumed to be an i3/NG PSAP.
8. If the location information delivered to the PSAP is a location-by-reference, the PSAP will send a dereference request to the element identified in the location reference (i.e., the LS) to obtain a *dispatch* location for the call.

5.1.2 Transitional/Interworking Architectures in Support of Emergency Calling

Although NG9-1-1 is defined to utilize an end-to-end IP architecture, there will continue to be legacy wireline and wireless (circuit switched) originating networks deployed after emergency service networks and a significant number of PSAPs have evolved to support NG9-1-1 architectures. Since any PSAPs served by NG Emergency Services Networks will need to be able to receive emergency calls that originate on these legacy networks, gateway functionality will be a required part of an NG9-1-1 Service Architecture. This gateway functionality must include signaling interworking to convert the incoming MF or SS7 signaling generated by a legacy origination network to the IP-based (i.e., SIP) signaling supported by an NG Emergency Services Network. In addition, since routing within the NG Emergency Services Network will be based on location, a gateway element on the ingress side of an NG Emergency Services Network must support the ability to use the information provided by a wireline switch or MSC in call setup signaling (e.g., calling number/ANI, ESRK, cell site/sector represented by an ESRD) to retrieve location information that can be used as input to routing determination. Based on the routing location provided, the

routing determination function will identify which Emergency Services Network should handle the call. Routing location will also be used to support routing within the NG Emergency Services Network. Gateway functionality will also be needed to enable interactions between NG Emergency Services Network elements (and the PSAPs they serve) and legacy systems, such as MPCs/GMLCs, to support the retrieval of dispatch location.

In addition to gateway functionality on the ingress side of an NG Emergency Services Network, there will be a need to support gateway functionality on the egress side of the NG Emergency Services Network. That is due to the fact that, while an increasing number of PSAPs will evolve to support NG functionality over time, NG Emergency Services Networks must be able to deliver emergency calls to interconnected legacy PSAPs. Thus the NG9-1-1 Service Architecture must include a functional element that will provide signaling interworking and other functionality necessary for emergency calls routed via the NG Emergency Services Network to be delivered to and handled by legacy PSAPs without requiring changes to legacy PSAP CPE. Calls routed via an NG Emergency Services Network and delivered to a legacy PSAP must undergo signaling interworking to convert the incoming IP-based (i.e., SIP) signaling supported by the NG Emergency Services Network to the Traditional MF or E-MF signaling supported by the legacy PSAP. Functionality must also be applied by the NG Emergency Services Network to emergency call originations to allow the legacy PSAP to experience call delivery, ALI data retrieval, and feature activation the same way as they do today.

5.1.2.1 Support for Interconnection of NG Emergency Services Networks & Legacy Originating Networks

To support emergency calls that originate in legacy networks, the NENA i3 Solution and ATIS IMS-based NG9-1-1 Service Architecture include the Legacy Network Gateway (LNG) functional element. The LNG logically resides between the originating network and the NG Emergency Services Network and allows PSAPs served by the NG Emergency Services Network to receive emergency calls from legacy originating networks. The LNG provides protocol interworking from the SS7 or MF signaling that it receives from a legacy originating network to the SIP signaling used in the NG Emergency Services Network. In addition, the LNG is responsible for routing emergency calls to the appropriate element in the appropriate NG Emergency Services Network. To support this routing function, the LNG applies NG9-1-1-specific interworking functionality to legacy emergency calls that allows the information provided in the call setup signaling by the wireline switch or MSC (e.g., calling number/ANI, ESRK, ESRD) to be used as input to the retrieval of routing location (in the form of a street address or geo-coordinate location) from an associated location server/database. The LNG uses this location information to query a call routing function to obtain routing information in the form of a URI. The LNG must then forward the emergency call/session request to a routing element in the NG Emergency Services Network, using the URI provided by the call routing function. The LNG will include callback and location information in the outgoing signaling.

The location server/database associated with an LNG must support mappings from a specific calling number/ANI or pANI (e.g., ESRK, ESRD) value to a location that will result in the emergency call being routed to the target PSAP associated with the calling number/ANI/pANI. In addition to identifying the location to be used for emergency call routing, the LNG is also responsible for providing dispatch location to PSAPs for emergency calls that originate in legacy networks. The mechanisms used by an LNG to access dispatch location are comparable to those used by an ALI system to provide dispatch location to a PSAP in an E9-1-1 environment (i.e., by accessing provisioned data and steering queries to MPC/GMLCs in wireless originating networks, as appropriate).

Figure 5.2 provides a high-level architecture diagram illustrating how emergency calls are processed using an interworking architecture involving an LNG.

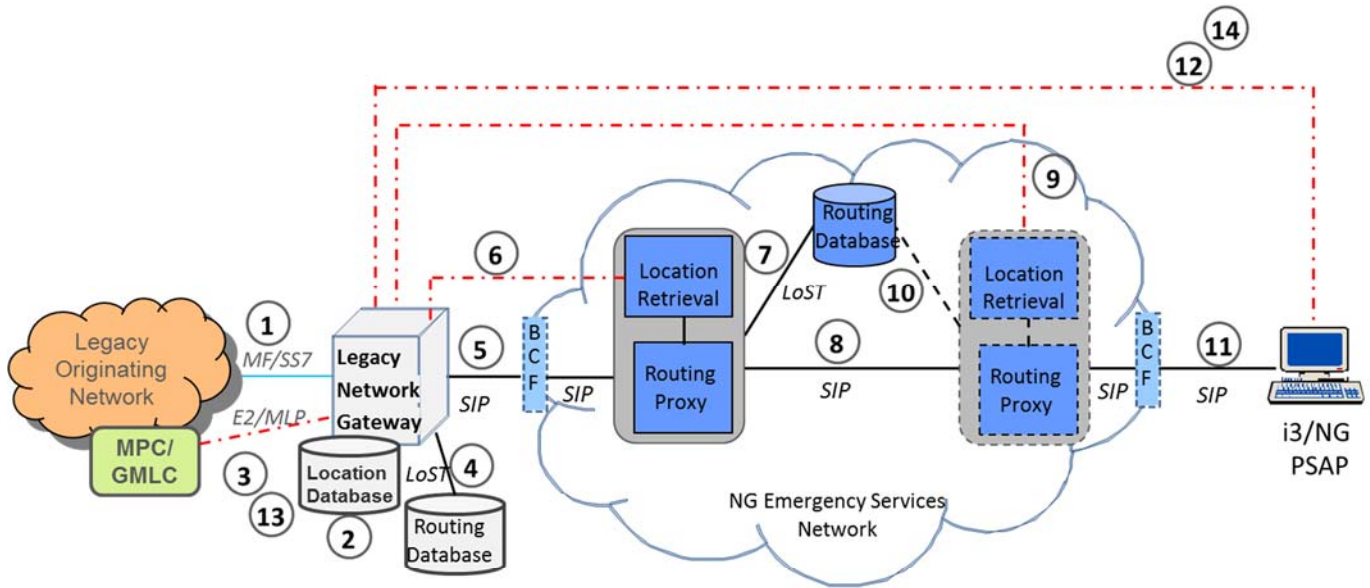

ALI – Automatic Location Identification
 BCF – Border Control Function
 GMLC – Gateway Mobile Location Center
 LNG – Legacy Network Gateway
 LoST – Location to Service Translation
 MF – Multi-Frequency
 MLP – Mobile Location Protocol

MPC – Mobile Positioning Center
 NG – Next Generation
 PSAP – Public Safety Answering Point
 SIP – Session Initiation Protocol
 SR – Selective Router
 SRDB – Selective Router Database
 SS7 – Signaling System Number 7

Figure 5.2 – NG9-1-1 Service Architecture Involving Legacy Network Gateway

1. A 9-1-1 call is delivered by the legacy originating network to a Legacy Network Gateway (LNG) over an MF or SS7 trunk group.
 - Legacy wireline originations are delivered with the SS7 Calling Party Number or MF ANI.
 - Legacy wireless originations are delivered with an ESRK as the SS7 Calling Party Number or MF ANI, or with the Mobile Directory Number as the SS7 Calling Party Number/MF ANI and an ESRD/ESRK in the SS7 Generic Digits parameter/MF called number.
2. The LNG will interact with a local location database which will map the calling number/ANI/ESRK/ESRD to a routing location.
3. If the call is a legacy wireless emergency call, the LNG will also send an E2 or MLP query to the MPC/GMLC in the legacy wireless network requesting initial (dispatch) location.
 - The location query will include the ESRK or MDN + ESRK/ESRD.
 - The response from the MPC/GMLC will include initial (typically Phase I) location information.
4. The LNG queries a routing database using the routing location obtained in Step 2.
 - The LNG queries the routing database with the routing location and an appropriate service URN.
 - The routing database provides the address of a routing proxy in the NG Emergency Services Network.
5. The emergency call is delivered by the LNG (via a Border Control Function) to a routing proxy in the NG Emergency Services Network with a callback number and location information.
 - If the call is a legacy wireline emergency call, the location obtained in Step 2 will typically be delivered “by-value” and will be in the form of a civic location/street address.

ATIS-0500034

- If the call is a legacy wireless emergency call, the location will typically be delivered “by-reference” to allow location updates associated with the mobile caller to be requested.
6. If the location information is received “by-reference” the location retrieval functionality within or associated with the routing proxy will be invoked.
 - A dereference request will be sent to the LNG to obtain a routing location for the call; the LNG will return the routing location obtained in Step 2.
 - If location is received “by-value”, this step will be omitted.
 7. The routing proxy uses the location information received in incoming SIP signaling (location-by-value) or obtained by dereferencing a location-by-reference to query a routing database.
 - The routing database is queried using the LoST protocol.
 - The LoST routing query contains location information and an appropriate service identifier (i.e., a service URN in the “sos” family).
 - The routing response contains the address of the “next hop” in the call path, in the form of a URI.
 8. The routing proxy forwards the emergency call/session request (with the same callback and location information as it received in incoming SIP signaling) to the “next hop” element based on the URI received in the LoST response.
 - The “next hop” element may be the PSAP or it may be another routing proxy in the call path, depending on the way the NG9-1-1 Service Architecture is implemented.
 9. If the next hop in the call path is another routing proxy, and the location information was received in incoming SIP signaling “by-reference”, the routing proxy will invoke location retrieval functionality within or accessible to it to retrieve a routing location for the call.
 - A dereference request will be sent to the LNG, and the LNG will return the routing location obtained in Step 2.
 - If location is received “by-value”, this step will be omitted.
 10. If present in the call path, the routing proxy will use the location information received in incoming SIP signaling (location-by-value) or obtained by dereferencing a location-by-reference, along with a service URN, to query a routing database using the LoST protocol.
 11. The routing proxy forwards the emergency call/session request (with the same callback and location information as it received in incoming SIP signaling) to the “next hop” element based on the URI received in the LoST response.
 - In this example, the “next hop” is assumed to be the target PSAP for the emergency call.
 - In this example, the target PSAP is assumed to be an i3/NG PSAP.
 12. If the location information delivered to the PSAP is a location-by-reference, the PSAP will send a dereference request to the LNG to obtain a *dispatch* location for the call.
 13. If the location dereference request from the i3/NG PSAP indicates that initial location should be returned, the LNG will return the initial dispatch information obtained in Step 3. If the location dereference request from the i3/NG PSAP indicates that updated location should be returned, the LNG will send an E2 or MLP query to the MPC/GMLC requesting updated (i.e., Phase II) location.
 14. The LNG returns the updated location information to the i3/NG PSAP.

5.1.2.2 Support for Interconnection of NG Emergency Services Networks & Legacy PSAPs

In addition to supporting the delivery of emergency calls to NG PSAPs, NG Emergency Services Networks are required to support the delivery of emergency calls to legacy PSAPs. To support the delivery of emergency calls that are routed via NG Emergency Services Networks to a legacy PSAP, NG9-1-1 Service Architectures include a Legacy PSAP Gateway (LPG) that serves as the signaling and media interconnection point between the NG Emergency Services Network and the legacy PSAP. The LPG is expected to provide special processing of the information received in incoming (SIP-based) call setup signaling to facilitate call delivery to legacy PSAPs, to assist

ATIS-0500034

legacy PSAPs in obtaining the callback and location information necessary to handle the call and support the dispatch of emergency personnel, and to support feature functionality currently available to legacy PSAPs, such as call transfer. The SIP signaling delivered to an LPG by a NG Emergency Services Network will contain the same information as the SIP signaling that is delivered to an NG PSAP, including location information (by-reference or by-value) and callback information. The LPG will be responsible for interworking the SIP signaling to the Traditional MF or E-MF signaling that is appropriate for the interface over which the call will be delivered to the legacy PSAP. Traditional MF and E-MF interfaces to legacy PSAPs assume that callback information signaled to a PSAP will be in the form of a 7/10-digit NANP number. It is possible that the callback information delivered to an LPG with an emergency call (e.g., associated with a VoIP origination) will not be in the form of (or easily converted to) a 10-digit NANP number. If a PSAP is expecting to receive callback information delivered with the call in call setup signaling, and the callback information received by the LPG is not in the form of (or easily converted to) a 10-digit NANP number with an NPA that is appropriate for the target PSAP (i.e., consisting of one of four NPAs supported by a legacy PSAP that supports a Traditional MF interface), the LPG will perform a mapping from the callback information to a locally significant digit string that can be delivered to the legacy PSAP via Traditional MF or E-MF signaling (as appropriate for the PSAP). The locally significant digit string delivered to the PSAP will be of the form "NPD/NPA-511-XXXX". The LPG will use the same mechanism to map callback information to a locally significant digit string if the callback information received in call setup signaling is in the form of a 10-digit NANP number, but the NPA is not one that is supported by the PSAP.

Location information received by the LPG will be provided to the legacy PSAP outside of the call setup process via a legacy ALI interface. The LPG will look to the legacy PSAP like an ALI system and the legacy PSAP will query the LPG using the same interface as it would use to query an ALI database. Like an ALI system, when an LPG is queried with an ALI location key (i.e., callback number and/or pANI), the LPG will respond with the location and other non-location information, as appropriate for the query protocol used by the legacy PSAP. If the SIP signaling associated with an emergency call routed via the NG Emergency Services Network contains a location by value, the LPG will include that location information in the ALI response, formatted appropriately for the receiving PSAP. If the SIP signaling delivered by the NG Emergency Services Network to the LPG includes a location-by-reference, the LPG must first dereference the location-by-reference to obtain the location information to return to the PSAP in response to an ALI query.

If the PSAP expects to receive location information delivered with the emergency call, the LPG will generate a 10-digit key (pANI) and associate it with the location and other call information that was provided in the incoming SIP INVITE message from the NG Emergency Services Network. This pANI will be passed to the PSAP via the Traditional MF or E-MF interface (as appropriate for the PSAP) and will be used by the PSAP in the ALI query that it generates. If the PSAP expects to receive both callback and location information with the emergency call (i.e., via an E-MF interface) and a pANI of the form NPD/NPA-511-XXXX is sent in the MF sequence corresponding to the callback number, the same digit string can be generated by the LPG and delivered to the legacy PSAP as a pANI that represents the location information received by the LPG in incoming signaling.

Note that, like emergency calls from non-initialized mobile devices, legacy PSAPs will not be able to initiate a callback call if the callback information associated with the emergency call is not in the form of a NANP number.

The mechanisms used by LPGs to deliver emergency calls to legacy PSAPs when the callback information is not in the form of a 10-digit NANP number (or where the callback information is in the form of a NANP number but the NPA is not one that is supported by a target Traditional MF PSAP) can also be used to support the delivery of emergency calls from Nationwide Number Portability customers to legacy PSAPs that utilize a Traditional MF interface.

Figure 5.3 provides a high-level architecture diagram illustrating how emergency calls are processed using an interworking architecture involving an LPG.

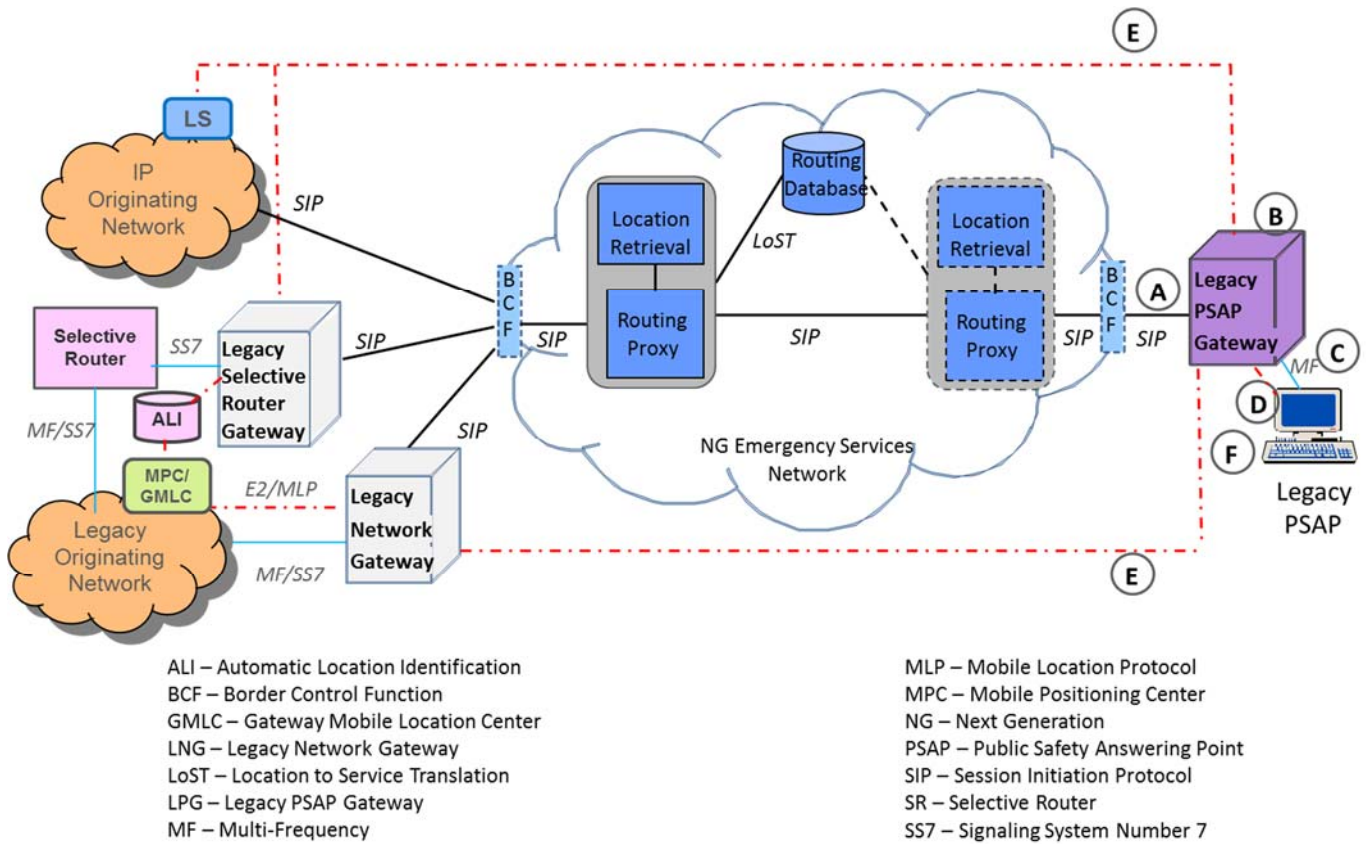

Figure 5.3 – NG9-1-1 Service Architecture Involving Legacy PSAP Gateway

An emergency call originates in an IP originating network or legacy originating network, and proceeds as described above to the point where the Route URI associated with the PSAP is obtained by a Routing Proxy. The emergency call, and associated data, is then processed as follows:

- A. The routing proxy forwards the emergency call/session request (with the **same** callback and location information as it received in incoming SIP signaling) via a BCF toward the legacy PSAP identified in the URI received in the response from the Routing Database.
 - The routing proxy forwards the SIP INVITE message to an LPG that is appropriate for the PSAP URI (i.e., an LPG to which the PSAP URI obtained from the routing database resolves).
- B. Upon receiving the emergency session request from the routing proxy, the LPG performs the following functions:
 - The LPG determines the type of interface supported by the target legacy PSAP.
 - Call delivery to legacy PSAPs is typically via a Traditional MF or E-MF interface.
 - A Traditional MF interface involves the signaling of an MF ANI sequence that consists of a Numbering Plan Digit (NPD) and a 7-digit ANI, where the value of the NPD represents one of four NPAs as well as an indication whether the ANI should be displayed using a steady display or a flashing display.
 - An E-MF interface supports the delivery of a 10-digit ANI with two ANI II digits and, optionally, a second 10-digit number (typically a pANI that represents the cell site/sector from which a legacy wireless call originated); the II digits indicate how the ANI should be displayed (i.e., steady or flashing).
 - If the PSAP supports a Traditional MF interface or an E-MF interface that only supports the delivery of one 10-digit number, the LPG will determine, based on per-PSAP provisioning,

ATIS-0500034

whether callback information or location information (i.e., a location key) should be signaled to the PSAP.

- If the LPG determines that **callback** information is to be signaled to the PSAP, the LPG will inspect the callback information to see if it is in the form of (or easily converted to) a 10-digit NANP number.
 - If callback information is to be delivered, and the callback information received in incoming SIP signaling is in the form of (or easily converted to) a 10-digit NANP number, and the NPA associated with that number is one that is appropriate for the target PSAP (i.e., one that can be mapped to an NPD digit), the LPG will use the received information to populate the 10-digit ANI signaled via E-MF or the NPD + 7-digit ANI sent via Traditional MF to the PSAP.
 - If callback information is to be delivered, and the callback information received in the incoming SIP signaling is **NOT** in the form of (or easily converted to) a 10-digit NANP number (or if the callback information is in the form of a 10-digit NANP number, but the NPA is not one that can be mapped to an NPD that is supported by a legacy PSAP via a Traditional MF interface), the LPG will generate a **substitute** ANI digit string of the form NPA-511-XXXX (for the E-MF case) or NPD + 511-XXXX (for the Traditional MF case, where the NPD is associated with an NPA that is appropriate for the target PSAP).
 - If the PSAP supports an E-MF interface, it supports the delivery of two 10-digit numbers and either callback or location information is not available, the LPG will signal the digits “000-911-0000” for the missing information.
 - If the LPG determines that **location** information is to be signaled to the PSAP, the LPG will generate a location key that is also of the form NPA-511-XXXX (for the Enhanced MF case) or NPD + 511-XXXX (for the Traditional MF case).
- C. The LPG delivers the emergency call to the PSAP using Traditional or E-MF signaling, as appropriate for the target PSAP.
- D. The PSAP uses the information provided via MF (i.e., the ANI and/or location key) to query the LPG as if it were a legacy ALI system.
- E. If the location information received by the LPG in incoming SIP signaling is “by-reference”, the LPG will send a dereference request to the element identified in the location reference (i.e., the LS in an IP originating network, or an LNG or an LSRG) to obtain a location value.
- Note that this step will be omitted if the location information received by the LPG in incoming SIP signaling was “by-value”.
- F. The LPG sends a response to the ALI request from the legacy PSAP that contains location information, callback information, and other non-location information (e.g., class of service, service provider contact information).

5.1.2.3 Support for Interconnection of NG Emergency Services Networks & Legacy Selective Routers

During the transition period while the Emergency Services infrastructure migrates toward IP, and PSAPs evolve to support i3 functionality, wireline and wireless callers and PSAPs that are served by legacy Selective Routers (SRs), will need to be supported. A Legacy Selective Router Gateway (LSRG) will provide the needed functionality to facilitate emergency call handling in transitional architectures where legacy SRs and ALIs are still present. The LSRG is a signaling and media connection point between a legacy SR and an NG Emergency Services Network. The LSRG allows emergency originations routed via a legacy SR to terminate on an NG PSAP, as well as allowing calls routed via an NG Emergency Services Network to terminate to a legacy PSAP that is connected to a legacy SR. The LSRG also facilitates transfers of calls between PSAPs that are served by legacy SRs and PSAPs that are served by NG Emergency Services Networks, regardless of the type of network from which the call originated.

Unlike an LNG, which only resides on the ingress side of the NG Emergency Services Network, or the LPG, which only resides on the egress side of the NG Emergency Services Network, an LSRG may reside on either the ingress

ATIS-0500034

1. A 9-1-1 call is delivered by the legacy originating network to a legacy SR over an MF or SS7 trunk group
 - Legacy wireline originations will be delivered with the SS7 Calling Party Number or MF ANI.
 - Legacy wireless originations will be delivered with an ESRK as the SS7 Calling Party Number or MF ANI, or with the Mobile Directory Number as the SS7 Calling Party Number/MF ANI and an ESRD/ESRK in the SS7 Generic Digits parameter/MF called number.
2. The SR queries an SRDB using the calling number/ANI, ESRK, or ESRD (based on the signaling received over the trunk group from the end office/MSC); the SRDB returns an ESN that points to a trunk group to an LSRG.
3. The SR delivers the emergency call to the LSRG over an SS7-supported trunk group.
 - The SS7 signaling will include the information (i.e., calling number/ANI, ESRK, ESRD) that the SR received from the end office/MSC.
4. The LSRG interacts with a local location database that maps the calling number/ANI/ESRK/ESRD to a routing location.
5. The LSRG also sends a query to the ALI system requesting dispatch location for the emergency call.
6. If the call is a legacy wireless emergency call, the ALI will send an E2 or MLP query to the MPC/GMLC in the legacy wireless network requesting initial (dispatch) location.
 - The location query will include the ESRK or MDN + ESRK/ESRD.
 - The response from the MPC/GMLC will include initial (typically Phase I) location information. Note that this step is omitted if the call is from a legacy wireline caller.
7. The ALI system then returns the information received from the MPC/GMLC to the LSRG.
 - If the call is a legacy wireline emergency call, the location obtained in Step 2 will typically be delivered “by-value” and will be in the form of a civic location/street address.
 - If the call is a legacy wireless emergency call, the location will typically be delivered “by-reference” to allow location updates associated with the mobile caller to be requested.
8. The LSRG queries a routing database using the routing location obtained in Step 4 and an appropriate service URN and receives the address of a routing proxy in the NG Emergency Services Network in response.
9. The emergency call is delivered by the LSRG (via a Border Control Function) to a routing proxy in the NG Emergency Services Network with a callback number and location information.
 - If the call is a legacy wireline emergency call, the location obtained in Step 4 will typically be delivered “by-value” and will be in the form of a civic location/street address; the callback number will be populated with the information received in the SS7 Calling Party Number parameter.
 - If the call is a legacy wireless emergency call, the location will typically be delivered “by-reference” to allow location updates associated with the mobile caller to be requested; the callback number will either be populated with the content of the SS7 Calling Party Number parameter (if both a calling number and an ESRD/ESRK was provided in the signaling from the SR), or with the callback number obtained from the MPC/GMLC (if only an ESRK was provided in call setup signaling from the SR).
10. If the location information is received by the routing proxy “by-reference”, the location retrieval functionality within or accessible to the routing proxy will be invoked. A dereference request will be sent to the LSRG to obtain a routing location for the call; the LSRG will return the routing location obtained in Step 4.

If location is received “by-value”, this step will be omitted.
11. The routing proxy uses the location information received in incoming SIP signaling (location-by-value), or obtained by dereferencing a location-by-reference, to query a routing database.
 - The routing database is queried using the LoST protocol.

ATIS-0500034

- The LoST routing query contains location information and an appropriate service identifier (i.e., a service URN in the “sos” family).
 - The routing response contains the address of the “next hop” in call path, in the form of a URI.
12. The routing proxy forwards the emergency call/session request (with the **same** callback and location information as it received in incoming SIP signaling) to the “next hop” element based on the URI received in the LoST response.
 - The “next hop” element may be the PSAP or it may be another routing proxy in the call path, depending on the way the NG9-1-1 Service Architecture is implemented.
 13. If the next hop in the call path is another routing proxy, and the location information was received in incoming SIP signaling “by-reference”, the routing proxy will invoke location retrieval functionality within or accessible to it to retrieve a routing location for the call. That is, the routing proxy will send a dereference request to the LSRG, and the LSRG will return the routing location obtained in Step 4.

If location is received “by-value”, this step will be omitted.
 14. If present in the call path, the routing proxy will use the location information received in incoming SIP signaling (location-by-value) or obtained by dereferencing a location-by-reference, and a service URN, to query a routing database using the LoST protocol.
 15. The routing proxy forwards the emergency call/session request (with the **same** callback and location information as it received in incoming SIP signaling) to the “next hop” element based on the URI received in the LoST response.
 - In this example, the “next hop” is assumed to be the target PSAP for the emergency call, and the target PSAP is an i3 PSAP.
 16. If the location information delivered to the PSAP is a location-by-reference, the PSAP will send a dereference request to the LSRG to obtain a *dispatch* location for the call.
 17. If the location dereference request from the i3/NG PSAP indicates that initial location should be returned, the LSRG will return the initial dispatch information obtained in Step 7.

If the location dereference request from the i3 NG/PSAP indicates that updated location should be returned, the LSRG will send a query to the ALI system requesting dispatch location for the emergency call.
 18. If the ALI receives a rebid request from the LSRG, the ALI will send an E2 or MLP query to the MPC/GMLC requesting updated (i.e., Phase II) location.
 19. The ALI returns the content of the MPC/GMLC response to the LSRG.
 20. The LSRG returns the updated location information to the i3/NG PSAP.

Egress LSRG

An emergency call that is routed via an NG Emergency Services Network and is destined for a legacy PSAP that is connected to an SR must traverse an LSRG on the egress side of the NG Emergency Services Network. Upon receiving an emergency session request from an NG Emergency Services Network, the LSRG will analyze the signaled information and apply NG9-1-1-specific processing to identify the outgoing trunk group over which the call will be delivered to the interconnected legacy SR, and to ensure that the information delivered to the legacy SR is in an acceptable format. The LSRG will select the outgoing route to the SR based on the destination PSAP number/address provided in the incoming SIP signaling from the NG Emergency Services Network. The LSRG maintains a mapping between the PSAP URI delivered to it in incoming SIP signaling and the Directory Number (DN) of the corresponding PSAP on the SR. The LSRG delivers the emergency call to the SR over an SS7-supported tandem-to-tandem trunk group. SS7 interfaces to legacy SRs assume that the PSAP DN and the callback information and/or location keys (i.e., pANIs) signaled to the legacy SR will be in the form of a 10-digit NANP number. It is possible that some emergency originations (e.g., from VoIP callers) will contain callback information that is not in the form of (or easily converted to) a 10-digit NANP number. If callback information is to be delivered to the SR (i.e., in the SS7 Calling Party Number parameter) and it is not in the form of (or easily converted to) a 10-digit NANP number, the LSRG will perform a mapping from the non-NANP callback information to a pseudo callback number that falls within the range of NPA-511-8950 through NPA-511-8999 (if the NPA is one of 281, 405, 806,

ATIS-0500034

870, and 903) or in the range NPA-211-9950 through NPA-211-9999 (for any other NPA in the United States), as appropriate for the destination PSAP.

The LSRG will also need to be able to pass a key to the location information associated with the emergency call to the SR, either by itself (i.e., populated in the SS7 Calling Party Number parameter) or in addition to the callback information (where the callback information will be populated in the SS7 Calling Party Number parameter and the location key will be populated in the SS7 Generic Digits Parameter). An egress LSRG must therefore also generate a 10-digit pANI to associate with the location information received in incoming signaling from the NG Emergency Services Network. If the location information received in incoming signaling from the NG Emergency Services Network contains a location-by-value, the LSRG will associate a pANI that falls within the range of NPA-511-8950 through NPA-511-8999 (if the NPA is one of 281, 405, 806, 870, and 903) or in the range NPA-211-9950 through NPA-211-9999 (for any other NPA), as appropriate for the destination PSAP. (Note that the same pANI can be used to represent both the callback and location information.)

If the location information received from the NG Emergency Services Network contains a location-by-reference, the LSRG will first check to see whether the location reference URI contains a value that is easily converted to a 10-digit NANP number (i.e., is of the form "+1NPANXXXXXX"). If the value of the location reference URI is of the form "+1NPANXXXXXX", the LSRG will use the NPA-NXX-XXXX portion of the location reference URI as the pANI that is the key to the location associated with the emergency call. If the content of the location reference URI is not of the form "+1NPANXXXXXX", the LSRG will use the mechanism described above for location-by-value to associate a pANI with the location information.

If the SR receives both a callback number (or pseudo callback number) and a pANI (associated with the location information), it will use per-PSAP provisioning to determine what will be signaled forward to the PSAP. The PSAP will use the information received in incoming signaling to query an ALI system to obtain the dispatch location for the call. The ALI will steer the location query back to the LSRG, in the same way as it would steer a location query to an MPC/GMLC in a wireless originating network. To support location delivery to legacy PSAPs that are served by legacy SRs, the LSRG must support an E2+ interface, as defined in NENA 05-001 or an MLP interface, as defined in OMA-TS-MLP-V3_2-20051124-C, as appropriate for the interconnected ALI system. The LSRG may also need to support a PSAP to ALI Messaging (PAM) interface, if it interconnects with ALI databases that use PAM to obtain location for legacy wireless emergency calls today. (Support for a PAM interface will be based on agreements between the LSRG provider and the ALI database provider.) The location key used in the E2+/MLP/PAM query will be the pANI (possibly in combination with the callback number/pseudo callback number) created by the LSRG for the emergency call. If the location information received from the NG Emergency Services Network is in the form of a location-by-value, the LSRG will be responsible for returning that location information, as well as the callback number and other non-location information, in the response to the ALI system. If the location information is in the form of a civic location/street address, the LSRG must ensure that location returned in the ALI response is in a format that is acceptable to the ALI system/PSAP. If the location information received by the NG Emergency Services Network is in the form of a location-by-reference, the LSRG will first have to dereference the location reference to obtain the location value to be returned in the response to the ALI system. Once again, if the location value is in the form of a civic location/street address, the LSRG will have to ensure that location returned in the ALI response is in an acceptable format.

Figure 5.5 provides a high-level architecture diagram illustrating how emergency calls are processed using a transitional architecture involving an egress LSRG.

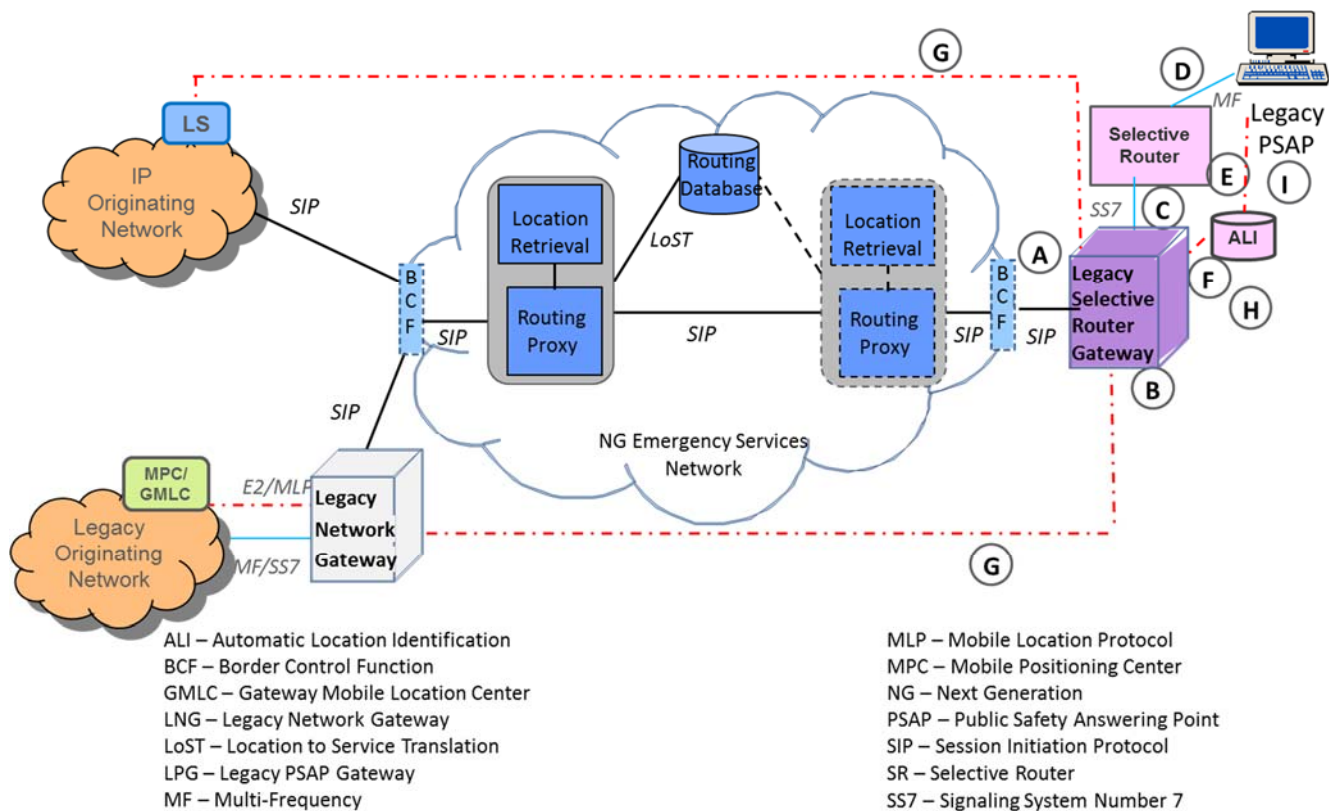

Figure 5.5 – NG9-1-1 Service Architecture Involving Egress Legacy Selective Router Gateway

An emergency call originates in an IP originating network or legacy originating network, and proceeds as described in the previous diagrams to the point where the Route URI associated with the PSAP is obtained by a Routing Proxy. The emergency call, and associated data, is then processed as follows:

- A. The routing proxy forwards the emergency call/session request (with the **same** callback and location information as it received in incoming SIP signaling) via a BCF toward the legacy PSAP identified in the URI received in the response from the Routing Database.
 - In this scenario, the target PSAP is a legacy PSAP that is still being served by a Selective Router.
 - The routing proxy forwards the SIP INVITE message to an LSRG that is appropriate for the PSAP URI (i.e., an LSRG to which the PSAP URI obtained from the routing database resolves).
- B. Upon receiving the emergency session request from the routing proxy, the LSRG performs the following functions:
 - The LSRG determines, based on provisioning, what information should be sent over the SS7-supported trunk group to the SR that serves the target PSAP.
 - The trunk group supports the delivery of a single 10-digit number (i.e., which will be populated in the SS7 Calling Party Number parameter) in addition to the PSAP directory number sent in the SS7 Called Party Number parameter.
 - The trunk group supports the delivery of two 10-digit numbers (i.e., one of which will be populated in the SS7 Calling Party Number parameter and the other in the SS7 Generic Digits Parameter) in addition to the PSAP directory number sent in the SS7 Called Party Number parameter.
 - In either case, the LSRG will associate an ESN-appropriate pANI with the location information received in incoming SIP signaling from the routing proxy.

ATIS-0500034

- If the LSRG determines that **callback** information is to be signaled to the SR along with the pANI/location key, the LSRG will inspect the callback information to see if it is in the form of (or easily converted to) a 10-digit NANP number.
 - If callback information is to be delivered, and the callback information received in incoming SIP signaling is in the form of (or easily converted to) a 10-digit NANP number, the LSRG will use the received information to populate the SS7 Calling Party Number parameter.
 - If callback information is to be delivered, and the callback information received in the incoming SIP signaling is **NOT** in the form of (or easily converted to) a 10-digit NANP number, the LSRG will generate a “pseudo callback number” (which may have the same value as the pANI described above) to populate in the SS7 Calling Party Number parameter.
- C. The LSRG routes the call to the legacy Selective Router over an SS7-supported trunk group.
- D. The Selective Router queries the SRDB (not shown) to obtain an ESN for the call (for potential use in Selective Transfer), and delivers the emergency call to the PSAP using Traditional or Enhanced MF signaling, as appropriate for the target PSAP.
- E. The PSAP uses the information provided via MF (i.e., the ANI and/or location key) to query the legacy ALI system.
- F. The ALI system steers the location query to the LSRG (as if it were an MPC/GMLC), using either the E2 protocol or MLP.
- G. If the location information received by the LSRG in incoming SIP signaling is “by-reference”, the LSRG will send a dereference request to the element identified in the location reference (i.e., the LS in an IP originating network, or an LNG) to obtain a location value.

Note that this step will be omitted if the location information received by the LSRG in incoming SIP signaling was “by-value”.
- H. The LSRG sends a response to the ALI that contains location information, callback information, and other non-location information (e.g., class of service, service provider contact information) as appropriate for the E2/MLP interface.
- I. The ALI sends a response to the PSAP that contains location information, callback information, and other non-location information, as appropriate for the interface protocol used between the ALI and the PSAP.

6 Detection of Failures in Emergency Call &/or Data Delivery

This clause describes the points in the legacy E9-1-1 and NG9-1-1 architectures where call, location, and callback information delivery failures can be detected.

6.1 Legacy E9-1-1 Environment

In a legacy E9-1-1 environment, the originating network has visibility into the emergency services network (i.e., the SR) with which it is interconnected, but not directly into the PSAP. The SR has visibility directly into the PSAP for call delivery, including the delivery of location keys and callback numbers in call setup signaling, but is not aware of what data is exchanged between the PSAP and the ALI system. In wireless E9-1-1 scenarios, an originating wireless network will be able to determine whether location (e.g., Phase II location) and a callback number are delivered to the ALI system, but will not be able to determine whether, or in what form, that information is presented to the PSAP. This clause analyzes where failures in call and data delivery may be detected in a legacy E9-1-1 environment.

Figure 6.1 illustrates a typical E9-1-1 environment that includes wireline, wireless, and Interim VoIP services interconnecting with the E9-1-1 network. The figure illustrates potential points of demarcation (e.g., Demarc 1) that

denote the logical boundaries of responsibility between providers². It also shows interfaces between different network elements: 1) between an originating network and the E9-1-1 network, 2) within the E9-1-1 network, and 3) between the E9-1-1 network and the PSAP CPE.

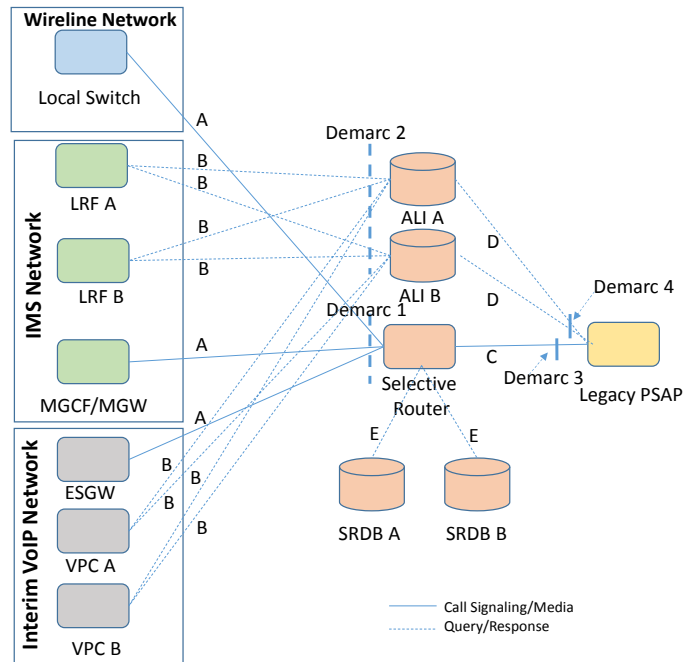

Figure 6.1 – Typical E9-1-1 Environment

6.1.1 Functional Elements

In Figure 6.1, IMS network elements are shown (Media Gateway Controller Function [MGCF]/Media Gateway [MGW] and Location Retrieval Function [LRF]). Legacy wireless network elements (Mobile Switching Center [MSC] and Global Mobile Location Center [GMLC]) can be extrapolated from this discussion.

Local Switch

The Local Switch in the Wireline Network interconnects to the SR with either CAMA or SS7 trunk groups. The number of trunks is engineered based upon the anticipation of the number of 9-1-1 calls that may occur.

Media Gateway Controller Function (MGC)/Media Gateway (MGW)

The MGCF/MGW in the IMS Network interconnects to the SR with either Feature Group D, CAMA, or SS7 trunk groups. The number of trunks is engineered based upon the anticipation of the number of 9-1-1 calls that may occur.

Location Retrieval Function (LRF)

The LRF contains the location of a mobile caller and is queried by the ALI to obtain initial and updated location.

² As described in NENA-INF-003, the parties responsible for network elements or functions on one side of a demarcation point are responsible for ensuring that those elements or functions are operating properly up to, but not beyond, that point. This responsibility does not imply ownership; elements of the network may be leased or provided by a third party.

Emergency Service Gateway (ESGW) of an Interim VoIP Network

The ESGW in the Interim VoIP Network interconnects to the SR with either Feature Group D, CAMA, or SS7 trunk groups. The number of trunks is engineered based upon the anticipation of the number of 9-1-1 calls that may occur.

VoIP Positioning Center (VPC) of an Interim VoIP Network

The VPC contains the location of the VoIP caller and is queried by the ALI to obtain the caller's location.

Selective Router

The selective routing function is a software capability on a Local Switch. Therefore, in addition to processing 9-1-1 calls, the local switch processes normal voice traffic. For example, when considering capacity planning, the aggregate of the types of traffic must be considered. Calls are selectively routed to the appropriate PSAP by querying the SRDB with a location key and obtaining an ESN that is associated with the trunk group to the PSAP.

Often, the SR is not deployed in a redundant configuration; so originating networks deliver all 9-1-1 calls to the same SR for the geographic area. The Dual Tandem configuration is discussed later in this clause.

Selective Routing Database

The SRDB may be deployed in either a standalone model or integrated into the SR. If the SRDB is deployed in the standalone model, the SRDB is deployed in a redundant configuration and the SR queries one of the databases to obtain routing information. If a query to one SRDB fails, the SR may query its redundant mate. The SR queries with the location key that it obtained from the originating network. Provisioned within the SRDB is the relationship of that location key to an ESN. The ESN may represent an ESZ or more generally a PSAP.

Automatic Location Information Database

For wireline 9-1-1 calls, the ALI provides the location information associated with the location key, which in this instance is the telephone number of the caller. For Wireless Phase I, the ALI may contain cell site information and if the PSAP queries with a location key (i.e., ESRD), the ALI will return the cell site location information. For some Wireless Phase I and all Wireless Phase II configurations, the ALI has to query (i.e., steer the location request to) the wireless network to obtain location information. As discussed earlier it may query an LRF with an ESRK or callback number and ESRD. For VoIP calls the ALI must steer the request to a VPC using an ESQK to obtain location information.

PSAP CPE

The PSAP receives a call request from the SR. However, due to the limitations of the signaling, a location key (which may also be the callback number [for wireline originations] or may be sent in combination with the callback number [for NCAS wireless emergency calls]) is sent to the PSAP from the SR. The PSAP then has to query the ALI to obtain location information using the location key and/or callback number.

6.1.2 Demarcation Points

Figure 6.1 illustrates demarcation points between network providers that denote where responsibility lies for managing and reporting failures. For a summarization of the Demarc Points and their relationship to their roles, see Annex A.

6.1.2.1 Demarc 1

The demarcation for call delivery is the "port" at the SR.

6.1.2.2 Demarc 2

For wireless and VoIP calls, the ALI must steer a query to an LRF or VPC, respectively. The originating carriers provide a connection to the data centers that host the ALIs.

6.1.2.3 Demarc 3

The E911SSP operating the SR must provide trunk group facilities to a demarcation point within the PSAP CPE. There may be other considerations for virtual PSAPs that are not covered in this document.

6.1.2.4 Demarc 4

The ALI provider, typically the same provider that operates the SR, must provide data facilities to the PSAP to facilitate ALI queries.

6.1.3 Interfaces

The interfaces defined here are between network elements and require network engineering considerations when deploying the system. Some interface reliability may be upgraded by increasing bandwidth, employing redundancy, etc.

6.1.3.1 Interface A

The trunk groups between the originating networks and the SR are engineered and managed by the originating network operator. That operator determines how many trunks are required to handle anticipated 9-1-1 traffic, often with the assistance of the E911SSP. The originating network provider may determine that they will provide only one trunk group on a single facility to the SR. They may determine that they will provide a single trunk group, but the individual trunks in that trunk group will have physical diversity.

In some cases wireless carriers have been requested to provide separate trunk groups to the SR for a specific PSAP jurisdiction. This is predicated on the considerations for default routing (called trunk routing) if there is a failure in the call set up (e.g., ANI failure).

6.1.3.2 Interface B

ALI steering links are required for wireless and VoIP originations to obtain caller location, which is hosted in the originating network. Since ALIs, LRFs, and VPCs are deployed in redundant configurations, the network elements must be fully interconnected. These data links are typically implemented using direct connect or VPN. The ALIs query on both links to the LRF or VPC and expect the response on one of the links (and just an ACK on the other).

6.1.3.3 Interface C

The SR has a trunk group to the PSAP that may use as signaling E-MF, CAMA-like (i.e., Traditional MF), or in limited cases ISDN. Normally neither the SR nor the PSAP equipment is physically redundant (see Dual Tandem below), and there is only a single trunk group across a single transport facility to the PSAP. In a few cases the SR may have physically redundant trunks within the trunk group. However, often they enter the building at the same ingress point.

6.1.3.4 Interface D

When the PSAP receives a call request from the SR it must query the ALI to obtain location information. The PSAP queries both redundant ALIs and obtains a "long message" (containing location information) from one and a "short" message (containing an ACK) from the other. As described above, the ALI may return information contained within its database or may query a wireless or Interim VoIP network to obtain the location information.

6.1.3.5 Interface E

If SRDBs are configured in a standalone model they are deployed in a redundant configuration. The SR queries one SRDB with the location key and receives an ESN in response. If the SR does not receive a response from one SRDB it will attempt a query to the other.

6.1.4 Considerations for Redundant SRs (Dual Tandems)

In order to improve reliability, there are a few E9-1-1 configurations that deploy redundant SRs for the same geographic area. This is called the Dual Tandem configuration. As shown in Figure 6.2, the network elements in the OSP network are required to deploy trunk groups to each of the redundant SRs. The OSP network may load-share traffic or may use an active/standby configuration. Each SR will have a link to the same PSAP, and an emergency call may be delivered to the PSAP from either of the SRs.

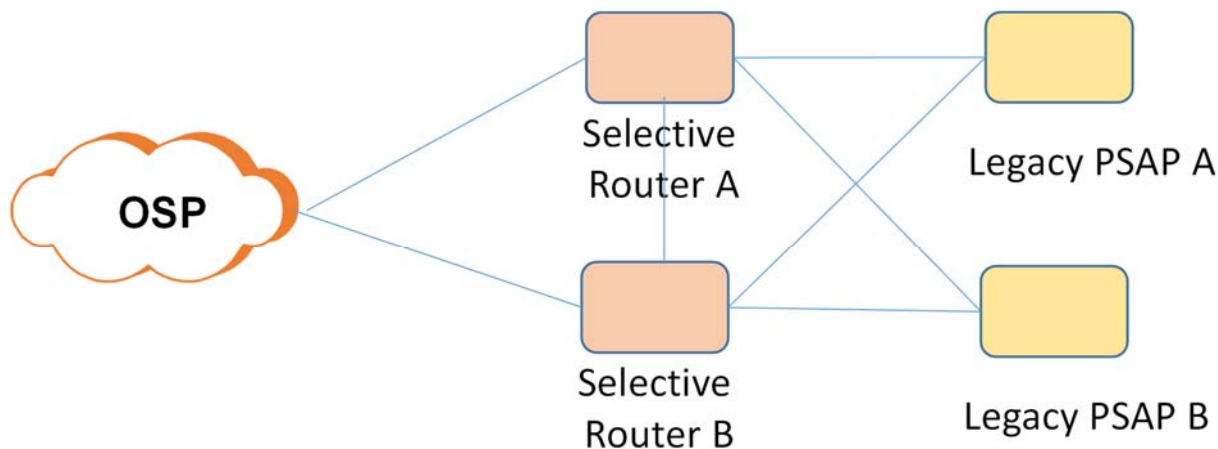

Figure 6.2 – Redundant SRs (Dual Tandems)

6.1.5 E9-1-1 Failure Considerations

In a legacy E9-1-1 environment, the originating network has visibility into the emergency services network (i.e., the SR [via Interface A] and, for wireless originations, the ALI [via Interface B]) with which it is interconnected, but it does not have visibility directly into the PSAP. The SR has visibility directly to the demarcation of the PSAP for call delivery (via Interface C), including the delivery of location keys and callback numbers in call setup signaling, but is not aware of what data is exchanged between the PSAP and the ALI system (via Interface D). In wireless E9-1-1 scenarios, an originating wireless network will be able to determine whether location (e.g., Phase II location) and a callback number are delivered to the ALI system (via Interface B), but will not be able to determine whether, or in what form, that information is presented to the PSAP (via Interface D). This clause analyzes where failures in call and data delivery may be detected in a legacy E9-1-1 environment.

6.1.5.1 Call Delivery Failures

6.1.5.1.1 Failures Detected by Originating Network Provider

Today, a legacy originating network monitors the 9-1-1 trunk groups that interconnect a wireline end office or MSC with an SR for alarms indicating the presence of failure conditions on those trunk groups. Wireline end offices and MSCs may also detect emergency call delivery failures via call failure indications or messages received in incoming signaling. Based on the signaling information received (e.g., the Cause Indicator parameter value in an SS7 Release message), the end office or MSC may be able to determine the nature of the failure and the network in which it occurred.

6.1.5.1.2 Failures Detected by E9-1-1 System Service Provider

An SR can detect when emergency message (i.e., SR-to-PSAP) trunks are unavailable, causing the call to be alternated routed or a PSAP to be isolated. Today, the E911SSP monitors emergency messaging trunks for blocked 9-1-1 calls resulting from trunk impairments. The E911SSP monitors transport alarms associated with emergency messaging trunks.

6.1.5.2 Location Information Delivery Failure

6.1.5.2.1 Failures Detected by Originating Network Provider

In a legacy wireline environment, caller location is provisioned by wireline service providers into the ALI system. The calling number/ANI associated with the caller serves as the location key and is delivered by the originating end office to the SR in call setup signaling. The originating service provider can only detect failures to deliver the calling number/ANI (i.e., the location key) to the SR. It has no knowledge of whether that location key was delivered to the PSAP or the PSAP was able to successfully obtain location information from the ALI system during the processing of a wireline emergency call.

For wireless emergency originations, the wireless service provider is responsible for delivering a location key in the form of an ESRK or ESRD to the SR in call setup signaling. The originating network provider is also responsible for responding to location requests (initial and updated/re-bids) from the ALI system. The wireless service provider will be able to detect whether there were any failures in the delivery of the ESRK/ESRD to the SR, and whether location requests from ALI systems were successfully processed, resulting in location information being returned to the ALI systems. Only if the wireless service provider subsequently receives a location request from an ALI system containing a specific ESRK/ESRD value can it conclude that the location key was successfully delivered to the PSAP by the SR. However, the lack of a location request from an ALI system does not definitively indicate that the ESRK/ESRD was not successfully delivered to the PSAP by the SR. The wireless service provider can also detect any failure to return location information in response to a request from an ALI system, but it will not be able to detect whether or not location information provided to the ALI system by the originating wireless network was successfully returned by the ALI system to the PSAP.

6.1.5.2.2 Failures Detected by E9-1-1 System Service Provider

In a legacy wireline environment, the E9-1-1 System Service Provider will be able to determine whether it received a calling number/ANI (i.e., the location key) in incoming signaling from the originating network and was able to successfully deliver that information to the target PSAP with the call. If the SR fails to receive a calling number/ANI in incoming signaling associated with a wireline emergency call, it will invoke default routing (based on the incoming trunk group), and will include a substitute ANI string (e.g., 0-911-0000 or 000-911-0000) in the signaling to the PSAP. If an ANI failure condition is encountered by an SR, the E9-1-1 System Service Provider can also conclude that an ALI failure has occurred, since the calling number/ANI is the key to the location information for a wireline emergency call.

If the E9-1-1 System Service Provider is also the ALI provider, then it will be able to determine whether or not location information associated with a legacy wireline origination was successfully returned to a PSAP in response to an ALI query from that PSAP containing the calling number/ANI as the location key.

In a legacy wireless environment, the E9-1-1 System Service Provider will be able to determine whether it received a location key in incoming signaling. If the originating network is using WCM operation, where the ESRK is delivered as the calling number/ANI and the call is marked as a wireline call, the E9-1-1 System Service provider need not make any distinction between receipt of an ESRK versus a calling number/ANI. The SR will apply the same default routing and substitute ANI sequence toward the PSAP as it would for a wireline call if there was no SS7 Calling Party Number or MF ANI received in incoming signaling from the originating network.

If the originating network is using NCAS operation, the E9-1-1 System Service Provider will be able to detect whether an ESRD/ESRK was received in an SS7 Generic Digits Parameter or as the MF called party number. The E9-1-1 System Service Provider will also be able to detect whether the location key was successfully delivered to the target PSAP for the call. If the SR does not receive an ESRD/ESRK associated with a wireless call (i.e., a call received over a trunk group that is marked as “wireless” or a call that is marked as “wireless” in incoming signaling),

it will apply default routing to the call, and will deliver the call to the default PSAP with the appropriate outgoing signaling information as determined by per-PSAP provisioning. Without the ESRK/ESRD, a PSAP will not be able to automatically retrieve (via the ALI system) location information associated with an emergency call from a legacy NCAS originating network. An E9-1-1 System Service Provider that detects a failure to receive an ESRD/ESRK and/or detects a failure to deliver the ESRD/ESRD to the PSAP can conclude that an ALI failure has also occurred.

If the E9-1-1 System Service Provider is also the ALI provider, it will be responsible for steering location queries to the wireless originating network and will be able to detect whether or not those queries result in the successful return of location information by the originating network. An E9-1-1 System Service Provider that is also an ALI provider will also be able to detect whether that location information was successfully returned by the ALI system to the PSAP.

6.1.5.3 Callback Information Delivery Failure

6.1.5.3.1 Failures Detected by Originating Network Provider

A legacy wireline originating network provider will be able to determine whether callback information was successfully passed in call setup signaling to an SR, but it will not be able to detect whether the callback information was successfully delivered to the PSAP. A legacy wireless originating network provider that is using NCAS operation will also be able to determine whether callback information was successfully delivered to the SR in call setup signaling, but will not be able to determine whether the callback information was delivered to the PSAP with the emergency call.

A legacy wireless originating network provider that is using WCM operation will not provide callback information in call setup signaling sent to the SR. Instead, callback information will be delivered to the ALI system (along with location information) in response to a location query from the ALI system³. Therefore, an originating network provider using WCM operation will be able to detect whether it has successfully delivered callback information associated with a WCM call to the ALI system, but will not be able to detect whether or not that callback information was successfully delivered by the ALI system to the PSAP.

6.1.5.3.2 Failures Detected by E9-1-1 System Service Provider

An E9-1-1 System Service Provider will be able to detect when it has received an SS7 Calling Party Number parameter or MF ANI sequence in incoming signaling, however the information contained in the SS7/MF signaling may or may not actually be the callback number. For example, if the emergency call originates in a legacy wireless network that uses WCM, the information in the SS7 Calling Party Number parameter/MF ANI will actually be the ESRK and not the callback number. The E9-1-1 System Service Provider will also be able to detect whether the information received in the SS7 Calling Party Number parameter or MF ANI was delivered to the PSAP via Traditional or Enhanced MF signaling. As described in Clause 6.1.5.2.2, if the SR fails to receive an SS7 Calling Party Number parameter or MF ANI associated with a wireline or wireless WCM emergency call, it will signal a substitute ANI string (e.g., 0-911-0TTT or 000-911-0TTT) forward to the PSAP. If the SR fails to receive an SS7 Calling Party Number parameter or MF ANI associated with an NCAS wireless emergency call, the information included in the outgoing MF signaling to the PSAP will depend on per-PSAP provisioning.

If the E9-1-1 System Service Provider is also the ALI provider, it will be able to determine whether callback information was included by the wireless originating network in the response to a location query from the ALI system. The E9-1-1 System Service Provider/ALI provider will also be able to detect any failures in the return of the callback information by the ALI system to the PSAP.

³ Note that in the case of an NCAS call, a callback number delivered to the PSAP in call setup signaling is expected to be included in the query from the ALI system and reflected back in the response to the ALI system.

6.1.6 Current E9-1-1 Reporting Metrics

6.1.6.1 Current FCC 911 Outage Reporting Mandates

The following is taken from FCC 15-9, PS Docket No. 07-114, 4th Report and Order [Ref 2]:

4.5 e *An outage that potentially affects a 911 special facility occurs whenever:*

- (1) There is a loss of communications to PSAP(s) potentially affecting at least 900,000 user-minutes and: The failure is neither at the PSAP(s) nor on the premises of the PSAP(s); no reroute for all end users was available; and the outage lasts 30 minutes or more; or*
- (2) There is a loss of 911 call processing capabilities in one or more E-911 tandems/selective routers for at least 30 minutes duration; or*
- (3) One or more end-office or MSC switches or host/remote clusters is isolated from 911 service for at least 30 minutes and potentially affects at least 900,000 user-minutes; or*
- (4) There is a loss of ANI/ALI (associated name and location information) and/or a failure of location determination equipment, including Phase II equipment, for at least 30 minutes and potentially affecting at least 900,000 user-minutes (provided that the ANI/ALI or location determination equipment was then currently deployed and in use, and the failure is neither at the PSAP(s) or on the premises of the PSAP(s)).*

6.1.6.2 Adopted 911 Outage Reporting Changes Approved in 2016 with a 12 Month Implementation Period

The following is taken from FCC 16-63, FNPRM PS Docket No. 11-82 [Ref 4]:

“We adopt the proposal in the Notice to specify that a “loss of communications” should trigger part 4 reporting obligations in the same way as a “network malfunction or higher-level issue that significantly degrades or prevents 911 calls from being completed to PSAPs.”

We provide that a “loss of communications” occurs when at least 80 percent of a 911 service provider’s trunks serving a PSAP (i.e., trunks over which the 911 service provider has control) become impaired to the point that they cannot support 911 call delivery in accordance with the Commission’s rules, including the information typically delivered with 911 calls. In other words, a 911 service provider would not need to report when 80 percent of its trunks go down if the remaining 20 percent could support delivery of 911 calls, including the number and location information, but it must report if not all 911 traffic can be re-routed, or if the re-routed traffic cannot be delivered without stripping it of number or location information.”

6.2 NG9-1-1 Environment

In an NG9-1-1 environment, the originating network only has visibility into the demarcation points at the boundaries of the emergency services network through which it is interconnected, but not directly into the PSAP. The emergency services network (including the LPG) has visibility directly into the PSAP for call delivery, including the delivery of location keys and callback numbers in call setup signaling. Only the LPG is aware of what data is exchanged between the PSAP and the external data sources (e.g., LIS, LRF, etc.). In NG9-1-1 scenarios, the originating network will be able to determine whether location and a callback number are delivered to the emergency services network, but will not be able to determine whether, or in what form, that information is presented to the PSAP. This clause analyzes where failures in call and data delivery may be detected in an NG9-1-1 environment.

Figure 6.3 illustrates the NG9-1-1 environment where calls from legacy networks are delivered to an LNG to be routed toward the PSAP, and IP-based originating network (e.g., IMS and generic IP-based networks) deliver native SIP requests to the emergency services network to be routed toward the PSAP. The figure illustrates potential points of demarcation (e.g., Demarc 1) that denote the logical boundaries of responsibility between providers. The figure applies the concept of demarcation points, as defined in NENA-INF-003 [Ref **Error! Reference source not**

found.]², to the NG9-1-1 environment. It also shows interfaces between different network elements: 1) between an originating network and the emergency services network; 2) within the emergency services network; and 3) between the emergency services network and the PSAP CPE (associated with both legacy and NG9-1-1 PSAPs).

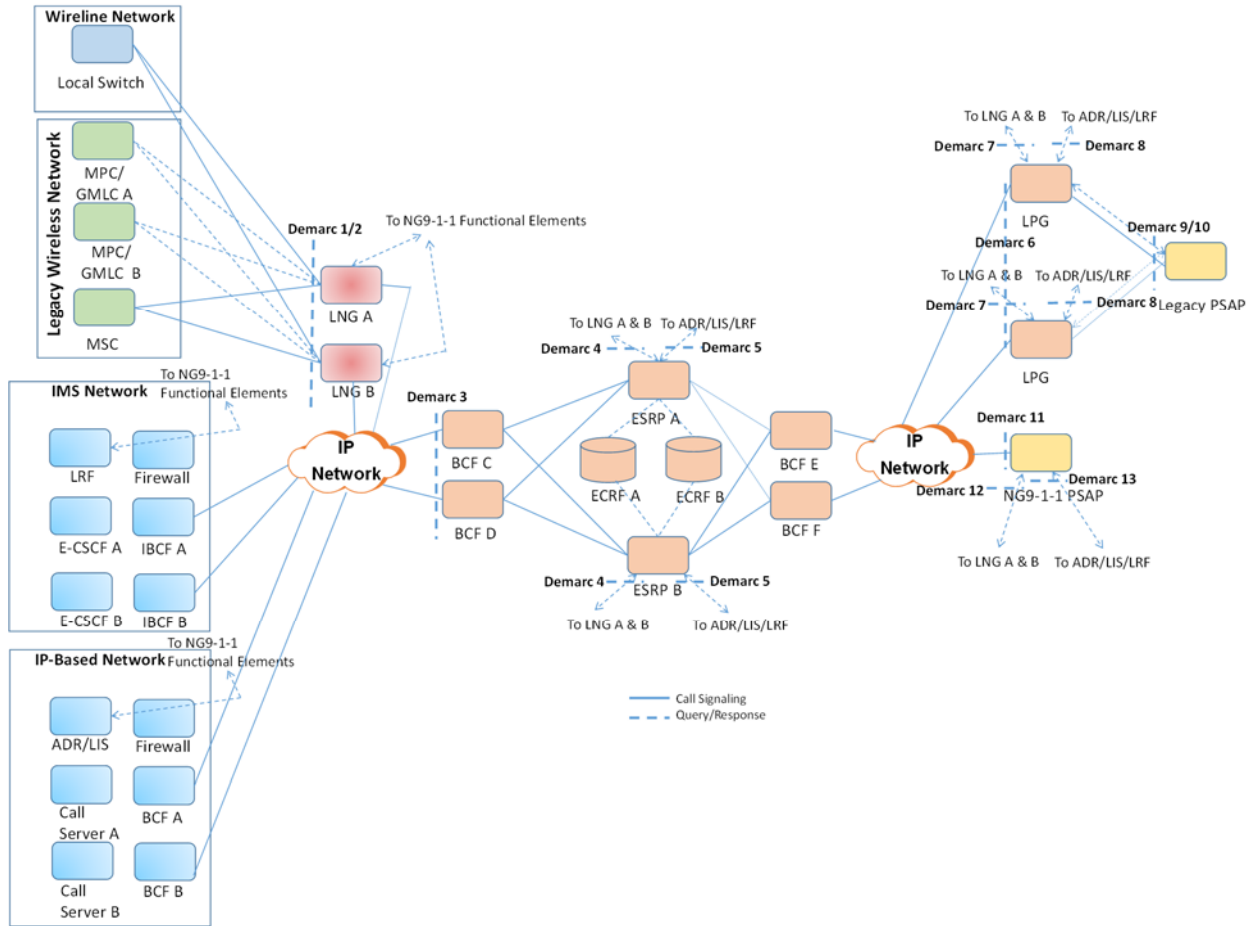

Figure 6.3 – NG9-1-1 Environment

6.2.1 Functional Elements

Local Switch

The Local Switch in the Wireline Network interconnects to the LNG with either CAMA or SS7 trunk groups. The number of trunks is engineered based upon the anticipation of the number of 9-1-1 calls that may occur.

Mobile Switching Center (MSC)

The MSC in the Wireless Network interconnects to the LNG with either Feature Group D, CAMA, or SS7 trunk groups. The number of trunks is engineered based upon the anticipation of the number of 9-1-1 calls that may occur.

Global Mobile Location Center (GMLC)

The GMLC contains the location of the mobile caller and is queried by the LNG to obtain initial or dispatch location. The LNG may also query the GMLC to obtain an updated location.

Emergency Call Session Control Function (E-CSCF)

The E-CSCF is the call routing function in the IMS originating network and interconnects with the emergency services network (via an IBCF) using native SIP. It may pass location and Additional Data by value or by reference.

Location Retrieval Function (LRF)

The LRF contains the location of a caller in the IMS network and is queried by the emergency services network elements or PSAP to obtain routing or dispatch location if the location was passed by reference; and may obtain an updated location if the caller is mobile. The LRF may also return Additional Data if the initial call request passed the Additional Data by reference.

VoIP Call Server

The Call Server is the call routing function in the generic IP-based originating network and interconnects with the emergency services network (via a BCF) using native SIP. It may pass location and Additional Data by value or by reference.

Location Information Server (LIS)

The LIS contains the location of a caller in the generic IP-based network and is queried by the emergency services network elements or PSAP to obtain routing or dispatch location if the location was passed by reference.

Additional Data Repository (ADR)

The ADR may reside in a generic IP-based network and contain Additional Data associated with the call. It is queried by emergency services network elements or PSAP if the initial call request passed the Additional Data by reference.

Legacy Network Gateway (LNG)

The LNG logically resides between the originating network and the emergency services network. Therefore based upon implementation, it may be the responsibility of the Originating Services Provider or the NG9-1-1 Service Provider (the concept of a third party is not discussed here). The LNG converts legacy signaling (e.g., SS7) to SIP and manages data connections to acquire location and potentially Additional Data.

Border Control Function (BCF)

BCFs (referred to as IBCFs in IMS networks) focus on the borders between two service provider networks in an IP peering environment and provide a demarcation point between them. A BCF provides a secure entry into the emergency services network for emergency calls presented to the network. The BCF incorporates firewall, admission control, and may include anchoring of session and media as well as other security mechanisms to prevent deliberate or malicious attacks on PSAPs or other entities connected to the emergency services network.

Emergency Services Routing Proxy (ESRP)

The ESRP is a functional element in an NG emergency services network which is a SIP proxy server that routes the call toward the PSAP based upon the PSAP URI it receives from the ECRF and other policy considerations.

Emergency Services Routing Function (ECRF)

The ECRF is the GIS-based routing determination functional element in the NG emergency services network that determines how the call request is to be routed. It receives a request from the ESRP and returns routing information in the form of a routing URI.

Legacy PSAP Gateway (LPG)

The LPG logically resides between the legacy PSAP and the NG emergency services network. The LPG supports the delivery of an emergency call received from an NG emergency services network to a legacy PSAP, as well as the transfer of an emergency call from/to a legacy PSAP. It also allows the legacy PSAP to query for location and Additional Data.

PSAP CPE

Two versions of PSAP CPE are supported in NG9-1-1: Legacy PSAP CPE and NG9-1-1 PSAP CPE. The Legacy PSAP receives a call request from the LPG. However due to the limitations of the signaling, a location key (which may also be the callback number [for wireline originations] or may be sent in combination with the callback number [for NCAS wireless or VoIP emergency calls]) is sent to the PSAP from the LPG. The Legacy PSAP then has to query the LPG to obtain location information and Additional Data using the location key and/or callback number.

The NG9-1-1 PSAP CPE receives a SIP call request from the ESRP in the emergency services network (via a BCF). The call request may contain location and Additional Data by value or by reference. If the NG9-1-1 PSAP receives location by reference it will query the originating network (e.g., LIS or LRF or LNG) to obtain location, and may re-query to obtain updated location information. If the NG9-1-1 PSAP CPE receives Additional Data by reference, it will query the originating network (e.g., ADR or LRF) to obtain additional data.

6.2.2 Demarcation Points

Figure 6.3 illustrates demarcation points between network providers that denote where responsibility lies for managing and reporting failures.

6.2.2.1 Demarc 1

This demarcation point applies if the LNG is operated by the NG9-1-1 Service Provider. It is between the LNG and a legacy originating network routing function (e.g., a Local Switch or MSC) and is at the “port” of the LNG.

6.2.2.2 Demarc 2

This demarcation point applies if the LNG is operated by the NG9-1-1 Service Provider. It is between LNG and the legacy wireless originating network location server (i.e., MPC/GMLC). The originating carriers provide a connection to the data centers that host the LNG.

6.2.2.3 Demarc 3

This demarcation point is between the IP-based originating network Border Control Function and the emergency services network Border Control Function for routing control. If the LNG is operated by any entity besides the NG9-1-1 Service Provider (e.g., the Originating Service Provider), this demarcation point is between the LNG and the emergency services network BCF. The demarcation is at the ingress of the emergency services network BCF.

6.2.2.4 Demarc 4

This demarcation point applies if the LNG is operated by any entity besides the NG9-1-1 Service Provider. If the location and/or the Additional Data is sent by reference, the ESRP will query the LNG for it. The demarcation is at the ESRP (note firewalls are included in the path, but not shown).

6.2.2.5 Demarc 5

This demarcation point is between the ESRP and the location server in an IP-based originating network (e.g., LIS or LRF) and/or the ADR in an IP-based originating network. The demarcation is at the ESRP (note firewalls are included in the path, but not shown).

6.2.2.6 Demarc 6

This demarcation point applies if the LPG is *not* operated by the NG9-1-1 Service Provider. The demarcation point is at the ingress of the LPG (note that the LPG may have an additional BCF, not shown).

6.2.2.7 Demarc 7

This demarcation point applies if the LPG and LNG are *not* operated by the same provider. The LPG would query the LNG for location and Additional Data if they were provided by reference.

6.2.2.8 Demarc 8

This demarcation point is between the LPG and the location server (e.g., LIS or LRF) and/or the ADR in an IP-based originating network. The demarcation is at LPG (note firewalls are included in the path, but not shown).

6.2.2.9 Demarc 9

This demarcation point is between the LPG and legacy PSAP to deliver calls over TDM circuits. The demarcation is at the PSAP CPE. This demarcation point applies if the LPG is operated by the NG9-1-1 Service Provider.

6.2.2.10 Demarc 10

This demarcation point is between the LPG and legacy PSAP to provide legacy ALL-equivalent data (location information and additional data). The demarcation is at the PSAP CPE. This demarcation point applies if the LPG is operated by the NG9-1-1 Service Provider.

6.2.2.11 Demarc 11

This demarcation point is between ESRP (via the BCF) and the NG9-1-1 PSAP to deliver the call request. It is at the PSAP CPE (note a BCF may be included at the PSAP, but not shown).

6.2.2.12 Demarc 12

If the location and/or the Additional Data is sent by reference, the NG9-1-1 PSAP will query the LNG for it. The demarcation is at NG9-1-1 PSAP (note firewalls are included in the path, but not shown).

6.2.2.13 Demarc 13

This demarcation point is between the NG9-1-1 PSAP and the location server (e.g., LIS or LRF) in an IP-based originating network and/or the ADR in an IP-based originating network. The demarcation is at NG9-1-1 PSAP (note firewalls are included in the path, but not shown).

6.2.2.14 Minimum Demarcation Points for the Typical NG9-1-1 Configuration

Figure 6.3 illustrates all of the possible demarcation points in an NG9-1-1 configuration. In configurations being deployed today it is typical for the gateway functions (LNG and LPG) to be the responsibility of the NG9-1-1 Service Provider. In that case the minimum number of demarcation points required to evaluate reporting criteria are shown below.

- Demarc Point 1
- Demarc Point 2

- Demarc Point 3 (only for ingress IP)
- Demarc Point 5
- Demarc Point 8
- Demarc Point 9
- Demarc Point 10
- Demarc Point 11
- Demarc Point 12
- Demarc Point 13

6.2.3 NG9-1-1 Failure Considerations – All-IP End-State

In an end-state (all-IP) NG9-1-1 environment, the originating network has visibility into the emergency services network (i.e., via Demarc Point 3) for call delivery and for location/Additional Data delivery where that information is signaled forward “by-value”. The originating network also has visibility into the ESRP (i.e., via Demarc Point 5) and the i3 PSAP (i.e., via Demarc Point 13) for dereferencing of location information and Additional Data that was signaled forward by the originating network “by-reference”. The originating network does not have visibility into the PSAP for call delivery or for information (i.e., location or Additional Data) delivery where that information was signaled by the originating network “by-value”. The NG Emergency Services Network has visibility directly into the PSAP (i.e., via Demarcation Point 11) for call delivery, including the delivery of location and Additional Data (“by-reference” or “by value”), as well as callback information, via SIP-based call setup signaling, but it is not aware of what data may be exchanged between the PSAP and the originating network (i.e., via Demarc Point 13). This clause analyzes where failures in call and data delivery may be detected in an NG9-1-1 environment.

6.2.3.1 Call Delivery Failures

6.2.3.1.1 Failures Detected by Originating Network

An IP-based originating network will be expected to monitor for transport alarms associated with IP connections to the NG Emergency Services Network. An IP originating network may also detect emergency call delivery failures via call failure indications/messages received via signaling. Based on the signaling indications received, the originating network may be able to determine the nature and location of the failure.

6.2.3.1.2 Failures Detected by the NG9-1-1 System Service Provider

An NG9-1-1 System Service Provider (SSP) will be able to detect when IP connectivity to the PSAP, or IP connectivity between the first routing element in the NG Emergency Services Network and other downstream network elements, is unavailable, resulting in alternate routing of the emergency call or PSAP isolation. The NG911SSP will be responsible for monitoring IP connections for transport alarms. Where appropriate, heartbeats may be used to verify the availability of network facilities. NG911SSPs should provide the means for capturing network traffic, generating alarms, and producing other metrics for monitoring and troubleshooting outages within NG Emergency Services Networks, as well as those impacting the ability of an NG Emergency Services Network to deliver calls to the target PSAP.

6.2.3.2 Location Delivery Failures

6.2.3.2.1 Failures Detected by Originating Network Providers

IP-based originating network providers will have the ability to determine whether or not location information is included in the outgoing SIP signaling sent to an NG Emergency Services Network. If the originating network provider fails to include location information (by-value or by-reference) in outgoing SIP signaling to an NG Emergency Services Network, it can conclude that location information was not delivered to the PSAP.

If the IP-based originating network provider is serving fixed customers, and location information is included in outgoing SIP signaling sent to the NG Emergency Services Network, the location information delivered to the NG Emergency Services Network (i.e., via Demarc Point 3) with the call will typically be in the form of location-by-value.

An originating network provider that delivers location-by-value to an NG Emergency Services Network will not be able to determine whether or not that location information is subsequently delivered to the PSAP.

IP-based originating network providers that serve mobile callers will be responsible for providing caller location dynamically per call. To support the dynamic delivery of location information associated with emergency calls originated by mobile users, the IP-based originating network will provide location-by-reference in the SIP signaling delivered to the NG Emergency Services Network via Demarc Point 3. The originating network provider must also support location dereference requests from routing elements in the NG Emergency Services Network (via Demarc Point 5) as well as NG PSAPs (via Demarc Point 13). If an IP-based originating network receives a dereference request from an NG PSAP, it can conclude that the location-by-reference that it signaled to the NG Emergency Services Network was successfully delivered to the NG PSAP. In addition, the IP-based originating network will be able to detect any failures to provide location-by-value in response to location dereference requests from NG Emergency Services Network elements or NG PSAPs.

6.2.3.2.2 Failures Detected by NG9-1-1 System Service Providers

Routing elements in an NG Emergency Services Network will be able to detect failures in the delivery of location information to the NG Emergency Services Network. If the IP-based originating network fails to provide location information to the NG Emergency Services Network in the SIP signaling associated with an emergency call, the NG emergency services network will perform default routing of the emergency call. The NG Emergency Services Network will be able to determine whether location information received from the originating network (“by-value” or “by-reference”) with the call is successfully delivered to the NG PSAP.

When a routing element in an NG Emergency Services Network receives location-by-reference, it will launch a dereference request to an element in the IP originating network. The NG911SSP will be able to detect failures in the dereference process if a routing element in the NG Emergency Services Network does not receive a location-by-value in response to the location dereference request.

6.2.3.3 Callback Information Delivery Failures

6.2.3.3.1 Failures Detected by Originating Network Providers

IP-based originating network providers have the ability to determine whether outgoing signaling delivered to an NG Emergency Services Network (via Demarc Point 3) includes callback information, but they will not be able to detect whether the callback information was successfully delivered to the PSAP.

6.2.3.3.2 Failures Detected by NG9-1-1 System Service Providers

NG911SSPs will be able to determine whether callback information was received in incoming signaling from an IP originating network, and will also be able to detect whether callback information was successfully delivered to the PSAP (i.e., via Demarc Point 11).

6.2.4 Interworking Architecture Involving Legacy Network Gateway

In an interworking architecture where a legacy originating network interfaces to an LNG that resides between the originating network and the NG Emergency Services Network, the amount of visibility that the originating network has into downstream elements/networks will depend on what entity has responsibility for the LNG and where the demarcation points are drawn. If the LNG is operated by the NG9-1-1 System Service Provider, then the originating network will only have visibility into what is delivered to the LNG to support call delivery (i.e., via Demarc Point 1) and location/Additional Data delivery (i.e., via Demarc Point 2). Call delivery from the originating network to the LNG will be via SS7 or MF trunk groups, with location delivered in the form of a 10-digit location key (i.e., calling number/ANI, ESRK, ESRD). If the LNG is operated by the originating network provider, then the originating network will also have visibility into the emergency services network for call delivery (i.e., via Demarc Point 3) and for location/Additional Data delivery (i.e., via Demarc Point 4). Using this type of arrangement, call delivery from the LNG to the emergency services network will be via SIP, with location and Additional Data delivered either “by value” or “by reference”.

If the NG9-1-1 System Service Provider operates the LNG, the originating network will have visibility into the LNG (i.e., via Demarc Point 2) to support location queries (using legacy protocols such as E2 or MLP) generated by the LNG to MPCs/GMLCs to obtain location and other information associated with legacy wireless emergency originations. If the originating network provider operates the LNG, the originating network provider will have visibility into the ESRP in the NG Emergency Services Network (i.e., via Demarc Point 4) and the i3 PSAP (i.e., via Demarc Point 13) for dereferencing of location information and Additional Data that was signaled forward by the LNG “by-reference”. Regardless of which network provider is responsible for operating the LNG, the originating network will not have visibility into the PSAP for call delivery or for information (i.e., location or Additional Data) delivery where that information was signaled by the originating network “by-value”. The entity that is responsible for operating the LNG will however have visibility into whether location or Additional Data was successfully delivered to the i3 PSAP “by reference” if the LNG receives a dereference request from the i3 PSAP (i.e., via Demarc 13).

The NG Emergency Services Network will have visibility directly into the PSAP (i.e., via Demarcation Point 11) for call delivery, including the delivery of location and Additional Data (“by-reference” or “by value”), as well as callback information, via SIP-based call setup signaling. This clause analyzes where failures in call and data delivery may be detected in an interworking environment where the service architecture includes an LNG.

6.2.4.1 Call Delivery Failures

6.2.4.1.1 Failures Detected by Originating Network Providers

A legacy originating network will be expected to monitor for transport alarms associated with SS7 or MF trunk groups to the LNG. If the originating network provider is also responsible for operating the LNG, the originating network will also be expected to monitor for transport alarms associated with IP connections to the NG Emergency Services Network. A legacy originating network may also detect emergency call delivery failures via call failure indications/messages received from the LNG via MF/SS7 signaling. Based on the signaling indications received, the originating network may be able to determine the nature and location of the failure. If the originating network provider is also responsible for operating the LNG, the originating network provider will also detect call delivery failure indications received by the LNG via SIP signaling.

6.2.4.1.2 Failures Detected by NG9-1-1 System Service Providers

As for the all-IP end state configuration, an NG911SSP will be able to detect when IP connectivity to the PSAP, or IP connectivity between the first routing element in the NG Emergency Services Network and other downstream network elements, is unavailable, resulting in alternate routing of the emergency call or PSAP isolation. The NG911SSP will be responsible for monitoring IP connections for transport and for capturing network traffic, generating alarms and producing other metrics for monitoring and troubleshooting outages within NG Emergency Services Networks, as well as those impacting the ability of an NG Emergency Services Network to deliver calls to the target PSAP.

If the NG911SSP is also responsible for operating the LNG, the NG911SSP will also be able to detect any errors in the SS7/MF call delivery signaling from the originating network.

6.2.4.2 Location Delivery Failures

6.2.4.2.1 Failures Detected by Originating Network Providers

Legacy originating network providers will have the ability to determine whether or not a calling number/ANI and/or a pANI (e.g., ESRK, ESRD) is included in the outgoing MF or SS7 signaling sent to an LNG (i.e., via Demarc Point 1) with an emergency call. If the originating network provider fails to include a calling number/ANI and/or a pANI in outgoing SS7 or MF signaling to LNG, it can determine that location information was not delivered to the PSAP.

If the originating network provider is also responsible for operating the LNG, the originating service provider will have the ability to determine whether or not location information is included in the outgoing SIP signaling sent by the LNG to an NG Emergency Services Network (i.e., via Demarc Point 3). If the originating network provider/LNG operator fails to include location information (by-value or by-reference) in outgoing SIP signaling to an NG Emergency Services Network, it can determine that location information was not delivered to the PSAP.

If the originating network provider is serving fixed customers, and location information is included in outgoing SIP signaling sent by the originating network provider/LNG operator to the NG Emergency Services Network, the location information delivered to the NG Emergency Services Network (i.e., via Demarc Point 3) with the call will typically be in the form of location-by-value. An LNG that delivers location-by-value to an NG Emergency Services Network will not be able to determine whether or not that location information is subsequently delivered to the PSAP by the NG Emergency Services Network.

Legacy wireless originating network providers that include a pANI in the SS7 or MF signaling sent to the LNG will be responsible for providing caller location when queried by an LNG (i.e., via Demarc Point 2) using the E2 protocol or MLP. If the legacy wireless originating network receives a request for updated dispatch location from an LNG, it can assume that the NG PSAP/LPG received a location-by-reference associated with the emergency call. The legacy wireless originating network provider will be able to determine whether the location request from the LNG was processed successfully, but unless they also operate the LNG, they will not know whether the location information was successfully returned to the NG PSAP/LPG. If the legacy wireless originating network provider operates the LNG, it will be able to determine whether location information (by-reference) was successfully provided by the LNG to the NG Emergency Services Network with the call using SIP signaling (i.e., via Demarc Point 3). An originating network provider that operates an LNG must also support location dereference requests from routing elements in the NG Emergency Services Network (via Demarc Point 4) as well as NG PSAPs (via Demarc Point 13). If an LNG receives a dereference request from an NG PSAP, it can conclude that the location-by-reference that it signaled to the NG Emergency Services Network was successfully delivered to the NG PSAP. In addition, the LNG will be able to detect any failures to provide location-by-value in response to location dereference requests from NG Emergency Services Network elements or NG PSAPs.

6.2.4.2.2 Failures Detected by NG9-1-1 System Service Providers

Routing elements in an NG Emergency Services Network will be able to detect failures in the delivery of location information to the NG Emergency Services Network. If the LNG fails to provide location information to the NG Emergency Services Network in the SIP signaling associated with an emergency call, the NG emergency services network will perform default routing of the emergency call. The NG911SSP will be able to determine whether location information received from the LNG (“by-value” or “by-reference”) with the call is successfully delivered to the NG PSAP (i.e., via Demarc 11) or the LPG (i.e., via Demarc Point 6).

When a routing element in an NG Emergency Services Network receives location-by-reference from an LNG, it will launch a dereference request back to the LNG to obtain the routing location. The NG911SSP will be able to detect failures in the dereference process if a routing element in the NG Emergency Services Network does not receive a location-by-value in response to the location dereference request.

If the NG911SSP is also responsible for operating the LNG, it will also have visibility into whether a location query initiated toward a legacy wireless network resulted in the successful return of location information, and whether location dereference requests from routing elements in the NG Emergency Services Network, NG PSAPs, or LPGs were successfully processed by the LNG.

6.2.4.3 Callback Information Delivery Failures

6.2.4.3.1 Failures Detected by Originating Network Providers

Legacy wireline originating network providers and legacy wireless originating network providers that use the NCAS method have the ability to determine whether outgoing MF or SS7 signaling delivered to an LNG (i.e., via Demarc 1) includes an MF ANI or SS7 Calling Party Number, but they will not be able to detect whether the callback information was successfully delivered to the PSAP. Legacy wireless originating network providers that use the WCM approach for emergency calls will be able to determine whether callback information is returned in response to an E2 or MLP request from an LNG (i.e., via Demarc Point 2).

If the legacy originating network provider also operates the LNG, it will be able to determine whether the SIP signaling delivered to the Emergency Services Network (via Demarc Point 3) includes callback information, but they will not be able to detect whether the callback information was successfully delivered to the PSAP.

6.2.4.3.2 Failures Detected by NG9-1-1 System Service Providers

NG911SSPs will be able to determine whether callback information was received in incoming signaling from an LNG, and will also be able to detect whether callback information was successfully delivered to an NG PSAP (i.e., via Demarc Point 11) or an LPG (i.e., via Demarc Point 6).

If the NG911SSP is also responsible for operating the LNG, it will also have visibility into whether callback information was delivered in call setup signaling (i.e., in the form of an MF ANI or SS7 Calling Party Number via Demarc Point 1), or whether it was obtained as part of the location response from a legacy wireless originating network (i.e., via Demarc Point 2).

6.2.5 Interworking Architecture Involving Legacy PSAP Gateway

In an interworking architecture where a legacy PSAP interfaces to an LPG that resides between the legacy PSAP and the NG Emergency Services Network, the amount of visibility that the NG Emergency Services Network has into the PSAP will depend on what entity has responsibility for the LPG and where the demarcation points are drawn. If the LPG is operated by the PSAP (or a third party other than the NG Emergency Services Network provider), then the NG Emergency Services Network will only have visibility into what is delivered to the LPG to support call delivery (i.e., via Demarc Point 6), including the delivery of location and Additional Data (“by-reference” or “by value”), as well as callback information, via SIP-based call setup signaling. It will not have visibility into what the LPG delivers to the PSAP with the call. The NG Emergency Services Network will also not be aware of what data may be exchanged between the LPG (on behalf of the PSAP) and the originating network (i.e., via Demarc Point 8), or between the LPG and the LNG (i.e., via Demarc Point 7).

If the LPG is operated by the provider of the NG Emergency Services Network (i.e., the NG911SSP), then in addition to having an awareness of the status of the IP connection between the NG Emergency Services Network and the LPG, and what information (e.g., callback information, location information “by-value” or “by-reference”, Additional Data “by value” or “by reference”) is delivered via SIP signaling to the LPG, the NG Emergency Services Network will have visibility directly into the PSAP (i.e., via Demarc Point 9) for call delivery. In this case, the NG911SSP will be aware of the status of the MF trunk group to the PSAP as well as what information is conveyed via Traditional MF or E-MF signaling between the LPG and the legacy PSAP. If the NG911SSP operates the LPG, then it will also have visibility into the delivery of location information and other additional data to the PSAP using legacy ALI query/response protocols (i.e., via Demarc Point 10). It will also be aware of whether or not dereference requests launched by the LPG toward the originating network (i.e., via Demarc Point 8) or toward an LNG (i.e., via Demarc Point 7) are successful in obtaining location information or Additional Data.

This clause analyzes where failures in call and data delivery may be detected in an interworking environment where the service architecture includes an LPG.

6.2.5.1 Call Delivery Failures

6.2.5.1.1 Failures Detected by Originating Network

The ability for an IP-based originating network to detect call delivery failures in an architecture where emergency calls are delivered to legacy PSAPs via an LPG will be the same as described in Clause 6.2.3.1.1. The only difference will be that the SIP-based call failure indications/messages will come from the LPG rather than from an NG PSAP. Likewise, the ability for a legacy originating network to detect call delivery failures in an architecture where emergency calls are delivered to legacy PSAPs via an LPG will be the same as described in Clause 6.2.4.1.1, except that if the originating network provider is also the LNG operator, the originating network provider will receive SIP-based call delivery failure indications from the LPG rather than from an NG PSAP.

6.2.5.1.2 Failures Detected by the NG9-1-1 System Service Provider

An NG911SSP will be able to detect when IP connectivity to the LPG is unavailable. The NG911SSP will be responsible for monitoring these IP connections for transport alarms. If the NG911SSP is also responsible for operating the LPG, then it will be able to detect when the MF (emergency message) trunks to the PSAP are unavailable, preventing calls from being delivered to the target legacy PSAP.

6.2.5.2 Location Delivery Failures

6.2.5.2.1 Failures Detected by Originating Network

The ability for an IP-based originating network to detect location delivery failures in an architecture where emergency calls are delivered to legacy PSAPs via an LPG will be the same as described in Clause 6.2.3.2.1, with the following clarification. The originating network provider must also support location dereference requests from LPGs (via Demarc Point 8), as well as routing elements in the NG Emergency Services Network (via Demarc Point 5) and NG PSAPs (via Demarc Point 13). If an IP-based originating network receives a dereference request from an LPG, it can conclude that the location-by-reference that it signaled to the NG Emergency Services Network was successfully delivered to the LPG, but it will not have visibility into whether or not location is successfully delivered to the legacy PSAP. In addition, the IP-based originating network will be able to detect any failures to provide location-by-value in response to location dereference requests from LPGs.

The ability for a legacy originating network to detect location delivery failures in an architecture where emergency calls are delivered to legacy PSAPs via an LPG will be the same as described in Clause 6.2.4.2.1, with the following clarification. An originating network provider that operates an LNG must support location dereference requests from LPGs (via Demarc Point 7), as well as from routing elements in the NG Emergency Services Network (via Demarc Point 4) and NG PSAPs (via Demarc Point 13). If an LNG receives a dereference request from an LPG, it can conclude that the location-by-reference that it signaled to the NG Emergency Services Network was successfully delivered to the LPG, but it will have no visibility into whether or not location information is successfully delivered to the legacy PSAP. The LNG will also be able to detect any failures to provide location-by-value in response to location dereference requests from LPGs.

6.2.5.2.2 Failures Detected by NG9-1-1 System Service Providers

The ability for an NG911SSP to detect location delivery failures in an architecture where emergency calls are delivered to legacy PSAPs via an LPG will be the same as described in Clauses 6.2.3.2.2 and 6.2.4.2.2, with the following clarifications. The NG911SSP will be able to determine whether location information received from the IP originating network or LNG (“by-value” or “by-reference”) with the call is successfully delivered to the LPG (i.e., via Demarc Point 6), but will not be able to determine whether location information was successfully delivered to the legacy PSAP unless the NG911SSP also operates the LPG.

If the NG911SSP is also responsible for operating the LPG, it will have visibility into whether a location dereference request initiated toward an originating network/LNG resulted in the successful return of location information to the LPG, and whether location information was successfully delivered to the legacy PSAP.

6.2.5.3 Callback Information Delivery Failures

6.2.5.3.1 Failures Detected by Originating Network Providers

IP-based originating network providers will have the ability to determine whether outgoing signaling delivered to an NG Emergency Services Network (via Demarc Point 3) includes callback information, but they will not be able to detect whether the callback information was successfully delivered to the LPG or the PSAP.

The ability for a legacy originating network to detect failures in the delivery of callback information in an architecture where emergency calls are delivered to legacy PSAPs via an LPG will be the same as described in Clause 6.2.4.3.1, with the following clarification. Legacy wireline originating network providers and legacy wireless originating network providers that use the NCAS method will be able to determine whether outgoing MF or SS7 signaling delivered to an LNG (i.e., via Demarc 1) includes an MF ANI or SS7 Calling Party Number, but they will not be able to detect whether the callback information was successfully delivered to the LPG or to the PSAP. If the legacy originating network provider also operates the LNG, it will be able to determine whether the SIP signaling delivered to the Emergency Services Network (via Demarc Point 3) includes callback information, but they will not be able to detect whether the callback information was successfully delivered to the LPG or to the PSAP.

6.2.5.3.2 Failures Detected by NG9-1-1 System Service Providers

NG911SSPs will be able to determine whether callback information was received in incoming signaling from an IP

originating network or LNG, and will also be able to detect whether callback information was successfully delivered to an LPG (i.e., via Demarc Point 6), but they will not be able to detect whether callback information was successfully delivered to the PSAP, unless the NG911SSP also operates the LPG. If the NG911SSP is also responsible for operating the LPG, it will have visibility into whether callback information was successfully delivered to the legacy PSAP.

6.2.6 Transitional Architecture Involving Legacy Selective Router Gateway

As described in Clause 5.1.2.3, the LSRG supports the delivery of emergency calls that originate in networks that are served by legacy SRs and are destined for PSAPs that are served by NG Emergency Services Networks, as well as the delivery of emergency calls routed via an NG Emergency Services Network to legacy PSAPs that are served by legacy SRs. The LSRG also facilitates transfers of calls between PSAPs that are served by legacy SRs and PSAPs that are served by NG Emergency Services Networks. An LSRG may reside on either the ingress or the egress side of an NG Emergency Services Network. While an LSRG is generally assumed to be operated by the same entity as operates the SR, there are demarcation points beyond those described in Clause 6.2.2 that are associated with transitional architectures that include LSRGs. These demarcation points influence the visibility that originating network providers and NG911SSPs have into potential failures that may occur with respect to emergency call delivery, location information delivery, and callback information delivery, when a transitional architecture involving LSRGs is used.

6.2.6.1 Ingress LSRG

In a transitional architecture where originating networks are served by legacy SRs and emergency calls are routed to NG Emergency Services Networks via an ingress LSRG, the amount of visibility that the originating network provider and NG911SSP have into downstream elements/networks will be similar to architectures involving an LNG, where the LNG is operated by the NG911SSP. A transitional architecture involving an ingress LSRG, with the associated demarcation points, is depicted below.

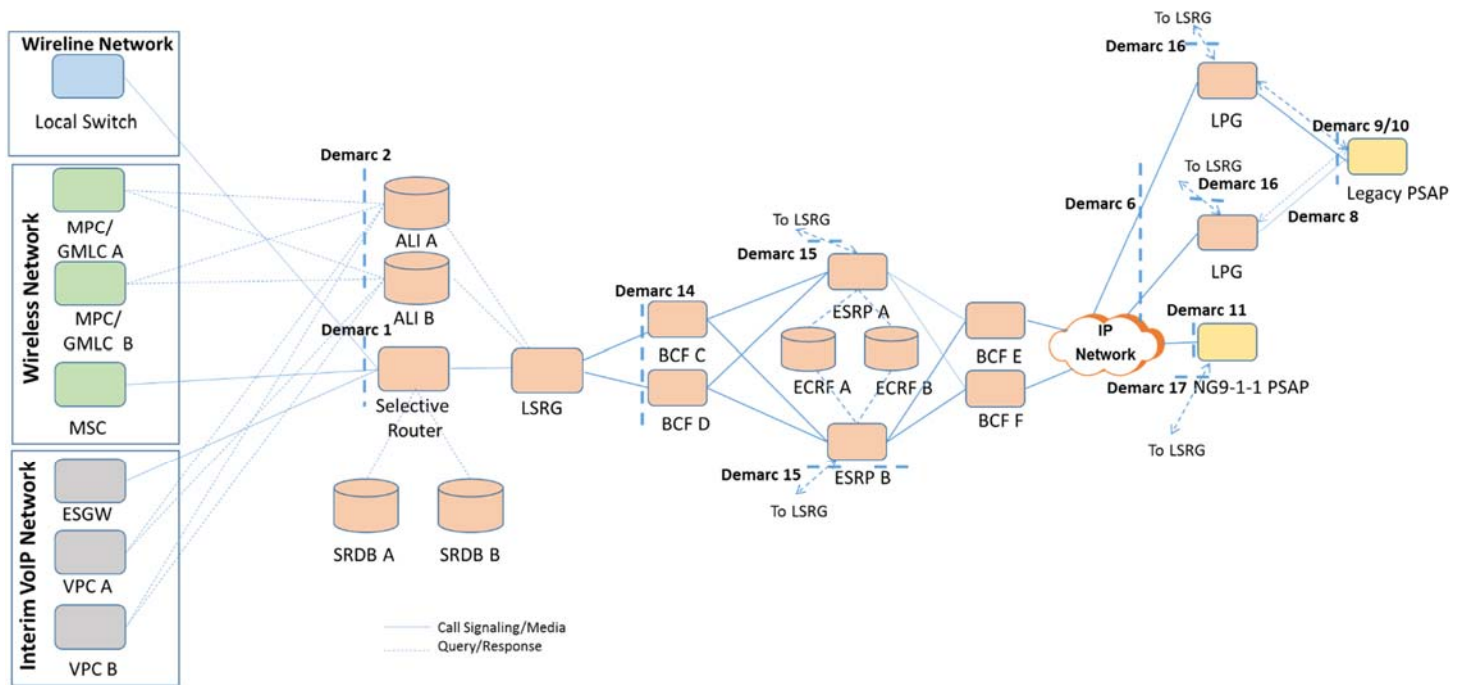

Figure 6.4 – Transitional Architecture with Ingress Legacy Selective Router Gateway

Figure 6.4 illustrates demarcation points between network providers that denote where responsibility lies for managing and reporting failures. Only the demarcation points that are unique to a transitional architecture that

ATIS-0500034

includes an ingress LSRG are defined below. See Clause 6.2.2 for descriptions of the other demarcation points included in this figure.

- **Demarc 14**
This demarcation point is between the ingress LSRG and the NG Emergency Services Network Border Control Function (BCF) and supports call delivery to the NG Emergency Services Network. The demarcation point is at the ingress to the emergency services network BCF.
- **Demarc 15**
If location and/or Additional Data is sent by the LSRG with the emergency call “by-reference”, the ESRP in the NG Emergency Services Network will send a dereference request to the LSRG to obtain the location/Additional Data “by-value”. The demarcation point that supports this dereferencing is at the ESRP (note firewalls are included in the path, but not shown).
- **Demarc 16**
This demarcation point applies if the architecture involves an LPG as well as an ingress LSRG. This demarcation point is used by the LPG to request the dereferencing of location and/or Additional Data if the location and/or Additional Data were provided by the ingress LSRG “by-reference”. The demarcation point is at the LPG (note firewalls are included in the path, but not shown).
- **Demarc 17**
If the location and/or the Additional Data is sent by the ingress LSRG “by-reference”, the NG9-1-1 PSAP will send a dereference request to the LSRG to obtain the location and/or Additional Data “by-value”. The demarcation point is at NG9-1-1 PSAP (note firewalls are included in the path, but not shown).

6.2.6.1.1 Call Delivery Failures

Failures Detected by Originating Network Providers

As in E9-1-1 architectures today, a legacy originating network will be expected to monitor for transport alarms associated with SS7 or MF trunk groups to the SR. A legacy originating network may also detect emergency call delivery failures via call failure indications/messages received from the SR via MF/SS7 signaling. Based on the signaling indications received (e.g., the Cause Indicator parameter value in an SS7 Release message), the originating network may be able to determine the nature and location of the failure.

Failures Detected by E9-1-1 System Service Providers

Since the E911SSP is also expected to be responsible for operating the ingress LSRG, the E911SSP will also be expected to monitor for transport alarms associated with IP connections to the NG Emergency Services Network. The E911SSP will also be able to detect call delivery failure indications received by the LSRG via SIP signaling from the NG Emergency Services Network.

Failures Detected by NG9-1-1 System Service Providers

As for the all-IP end state configuration and interworking architectures involving LNGs, an NG911SSP will be able to detect when IP connectivity to the PSAP, or IP connectivity between the first routing element in the NG Emergency Services Network and other downstream network elements, is unavailable, resulting in alternate routing of the emergency call or PSAP isolation. The NG911SSP will be responsible for monitoring IP connections for transport alarms associated with IP connections from ingress LSRGs and between elements within the NG Emergency Services Network. The NG911SSP will be responsible for capturing network traffic, generating alarms and producing other metrics for monitoring and troubleshooting outages within NG Emergency Services Networks, as well as those impacting the ability of an NG Emergency Services Network to deliver calls to the target PSAP.

6.2.6.1.2 Location Delivery Failures

Failures Detected by Originating Network Providers

As for interworking architectures involving LNGs, legacy originating network providers will have the ability to

ATIS-0500034

determine whether or not a calling number/ANI and/or a pANI (e.g., ESRK, ESRD) is included in the outgoing MF or SS7 signaling sent to an SR (i.e., via Demarc Point 1) with an emergency call. If the originating network provider fails to include a calling number/ANI and/or a pANI in outgoing SS7 or MF signaling to the SR, it can conclude that location information will not be delivered to the PSAP.

Legacy wireless originating network providers will be responsible for providing caller location when queried by a legacy ALI system (i.e., via Demarc Point 2) using the E2 protocol or MLP. If the legacy wireless originating network receives a request for updated dispatch location from a legacy ALI system, it can assume that the NG PSAP/LPG received a location-by-reference associated with the emergency call, and that the ingress LSRG received a dereference request from the NG PSAP/LPG (see below for further details). The legacy wireless originating network provider will be able to determine whether the location request from the legacy ALI system was processed successfully, but they will not know whether the location information was successfully returned to the NG PSAP/LPG.

Failures Detected by E9-1-1 System Service Providers

Since the E911SSP is assumed to also be responsible for operating the ingress LSRG, the E911SSP will have the ability to determine whether or not location information is included in the outgoing SIP signaling sent by the LSRG to an NG Emergency Services Network (i.e., via Demarc Point 14). If the E911SSP/LSRG operator fails to include location information (by-value or by-reference) in outgoing SIP signaling to an NG Emergency Services Network, it can conclude that location information was not delivered to the PSAP.

When the E911SSP receives emergency calls from a legacy wireline originating network provider, the location information delivered to the NG Emergency Services Network (i.e., via Demarc Point 14) with the call will typically be in the form of location-by-value. An LSRG that delivers location-by-value to an NG Emergency Services Network will not be able to determine whether or not that location information is subsequently delivered to the PSAP by the NG Emergency Services Network.

When the E911SSP receives an incoming emergency call from a legacy wireless originating network, the E911SSP will be able to determine whether location information (by-reference) was successfully provided by the LSRG to the NG Emergency Services Network with the call using SIP signaling (i.e., via Demarc Point 14). The E911SSP must also support location dereference requests to the ingress LSRG from routing elements in the NG Emergency Services Network (via Demarc Point 15) as well as NG PSAPs (via Demarc Point 17) and LPGs (via Demarc Point 16). If an LSRG receives a dereference request from an NG PSAP, it can conclude that that the location-by-reference that it signaled to the NG Emergency Services Network was successfully delivered to the NG PSAP. The E911SSP will also be able to detect any failures by the LSRG to provide location-by-value in response to location dereference requests from NG Emergency Services Network elements, NG PSAPs, or LPGs.

Failures Detected by NG9-1-1 System Service Providers

Routing elements in an NG Emergency Services Network will be able to detect failures in the delivery of location information to the NG Emergency Services Network. If an ingress LSRG fails to provide location information to the NG Emergency Services Network in the SIP signaling associated with an emergency call, the NG Emergency Services Network will perform default routing of the emergency call. The NG911SSP will be able to determine whether location information received from an ingress LSRG (“by-value” or “by-reference”) with the call is successfully delivered to the NG PSAP (i.e., via Demarc 11) or the LPG (i.e., via Demarc Point 6).

When a routing element in an NG Emergency Services Network receives location-by-reference from an ingress LSRG, it will launch a dereference request back to the LSRG to obtain the routing location. The NG911SSP will be able to detect failures in the dereference process if a routing element in the NG Emergency Services Network does not receive a location-by-value in response to the location dereference request.

The NG911SSP will not have visibility into location dereference requests initiated by NG9-1-1 PSAPs or LPGs toward ingress LSRGs.

6.2.6.1.3 Callback Information Delivery Failures

Failures Detected by Originating Network Providers

Legacy wireline originating network providers and legacy wireless originating network providers that use the NCAS method have the ability to determine whether outgoing MF or SS7 signaling delivered to an SR (i.e., via Demarc 1) includes an MF ANI or SS7 Calling Party Number, but they will not be able to detect whether the callback information was successfully delivered to the PSAP.

ATIS-0500034

Legacy wireless originating network providers that use the WCM approach for emergency calls will be able to determine whether callback information is returned in response to an E2 or MLP request from a legacy ALI (i.e., via Demarc Point 2). However, the originating network provider will not have visibility into the availability of that information to any other network element or PSAP.

Failures Detected by E9-1-1 System Service Providers

The E911SSP (which is assumed to also be responsible for operating the ingress LSRG) will have the ability to determine whether or not callback information was received from the originating network (i.e., via Demarc Point 2), in call setup signaling, and whether it is included in the outgoing SIP signaling sent by the LSRG to an NG Emergency Services Network (i.e., via Demarc Point 14) to establish the emergency call. An LSRG that delivers callback information to an NG Emergency Services Network will not be able to determine whether or not that callback information is subsequently delivered to the PSAP by the NG Emergency Services Network.

An E911SSP will also be able to recognize when an LSRG queries an ALI system for location/callback information, and the ALI system in turn queries the legacy wireless originating network for location/callback information using the E2 protocol or MLP. The E911SSP will be able to determine whether callback information was successfully obtained by the ALI system from the legacy wireless originating network (i.e., via Demarc Point 2), and was successfully delivered to the LSRG. As described above, the E911SSP will be able to determine whether callback information was successfully delivered to an NG Emergency Services Network in outgoing SIP signaling, but will not be able to determine whether callback information was successfully delivered to the PSAP.

Failures Detected by NG9-1-1 System Service Providers

NG911SSPs will be able to determine whether callback information was received in incoming signaling from an ingress LSRG (i.e., via Demarc Point 14), and will also be able to detect whether callback information was successfully delivered to an NG PSAP (i.e., via Demarc Point 11) or an LPG (i.e., via Demarc Point 6) in call setup signaling.

As described in Clause 6.2.5.3.2, an NG911SSP will not be able to detect whether callback information was successfully delivered to a legacy PSAP via an LPG, unless the NG911SSP also operates the LPG. If the NG911SSP is also responsible for operating the LPG, it will have visibility into whether callback information was successfully delivered to the legacy PSAP.

6.2.6.2 Egress LSRG

In a transitional architecture where an emergency call routed via an NG Emergency Services Network is delivered via an egress LSRG to a PSAP that is served by a legacy SR, the amount of visibility that the originating network provider and NG911SSP have into downstream elements/networks will be similar to architectures involving an LPG, where the LPG is operated by an entity other than the NG911SSP. A transitional architecture involving an egress LSRG, with the associated demarcation points, is depicted below.

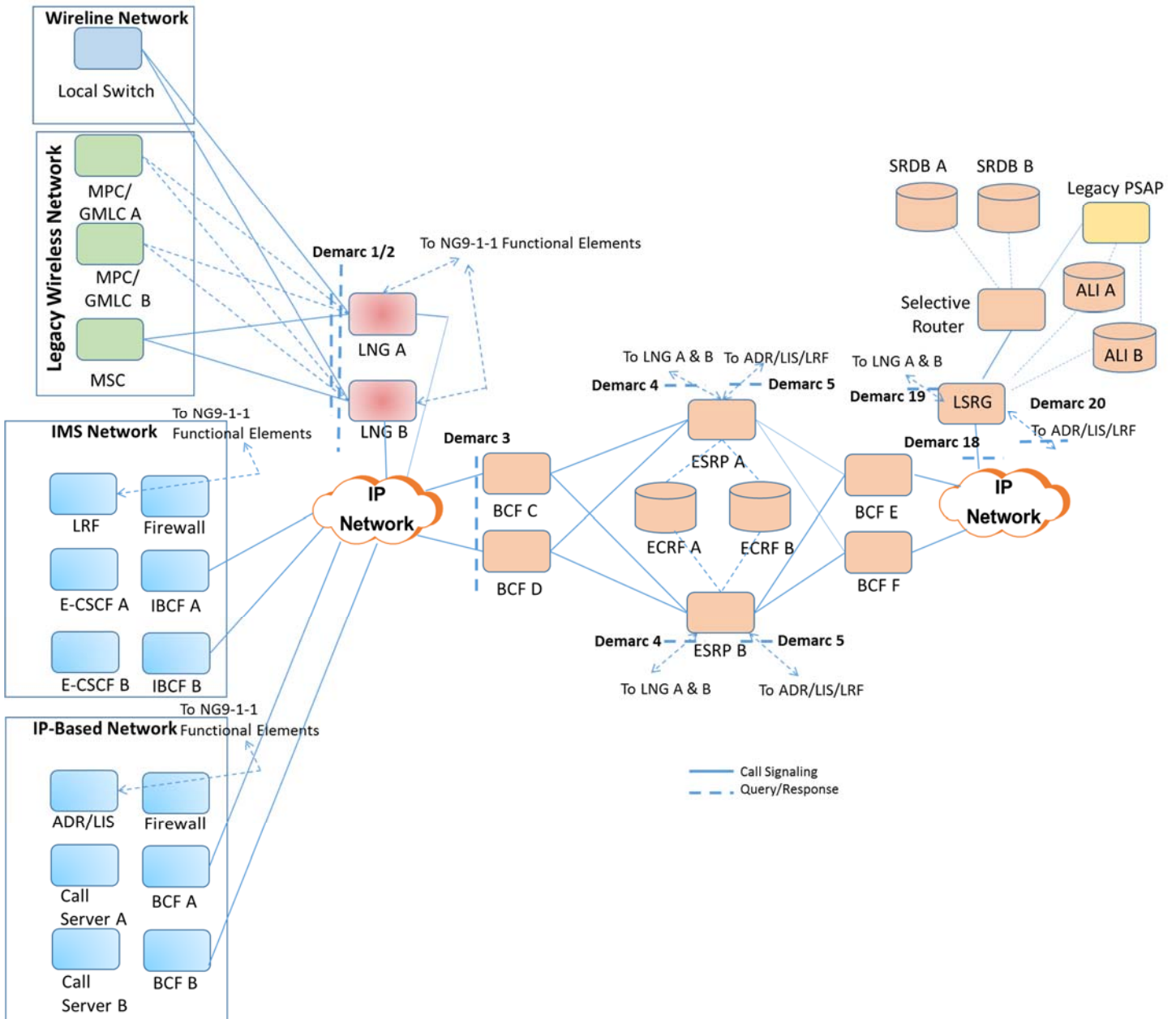

Figure 6.5 – Transitional Architecture with Egress Legacy Selective Router Gateway

Figure 6.5 illustrates demarcation points between network providers that denote where responsibility lies for managing and reporting failures. Only the demarcation points that are unique to a transitional architecture involving an egress LSRG are defined below. See Clause 6.2.2 for descriptions of the other demarcation points included in this figure.

- **Demarc 18**
This demarcation point is between the NG Emergency Services Network Border Control Function and the egress LSRG to support call delivery to a PSAP that is served by a legacy SR. The demarcation point is at the ingress side of the LSRG (note that the LSRG may have an additional BCF, not shown).
- **Demarc 19**
If location and/or Additional Data is generated by an LNG and delivered to the egress LSRG with the emergency call “by-reference”, the egress LSRG will send a dereference request to the LNG to obtain

the location/additional data “by-value”. The demarcation point that supports this dereferencing is at the egress LSRG (note firewalls are included in the path, but not shown).

- Demarc 20

This demarcation point is between the egress LSRG and the location server (e.g., LIS or LRF) and/or the ADR in an IP-based originating network. This demarcation point applies if the emergency call originates in an IP-based originating network and location and/or Additional Data is delivered to the egress LSRG “by-reference”. This demarcation point is used by the egress LSRG to request the dereferencing of location and/or Additional Data. The demarcation point is at the egress LSRG (note firewalls are included in the path, but not shown).

6.2.6.2.1 Call Delivery Failures

Failures Detected by Originating Network Providers

The ability for an IP-based originating network to detect call delivery failures in an architecture where emergency calls are delivered to legacy PSAPs via SRs that are connected to NG Emergency Services Networks via egress LSRGs is the same as described in Clause 6.2.3.1.1, with the exception that the SIP-based call failure indications/messages will come from the egress LSRG rather than from an NG PSAP.

The ability for a legacy originating network to detect call delivery failures in an architecture where emergency calls are delivered to legacy PSAPs via SRs that are interconnected to egress LSRGs is the same as described in Clause 6.2.4.1.1, except that if the originating network provider is also the LNG operator, the originating network provider will receive SIP-based call delivery failure indications (i.e., at the LNG) from the egress LSRG rather than from an NG PSAP.

Failures Detected by NG9-1-1 System Service Providers

An NG911SSP will be able to detect when IP connectivity to the egress LSRG (i.e., via Demarc Point 18) is unavailable. The NG911SSP will be responsible for monitoring these IP connections for transport alarms. The NG911SSP will not be able to detect when the MF (emergency message) trunks to the PSAP are unavailable. SIP-based call delivery failure indications generated by the egress LSRG in response to SS7 Release messages with certain Cause Indicator parameter values will be passed to the NG Emergency Services Network. This will allow the NG911SSP to indirectly detect when there is a failure to deliver an emergency call to a legacy PSAP that is served by an SR.

Failures Detected by E9-1-1 System Service Providers

Since the E911SSP is also expected to be responsible for operating the egress LSRG, the E911SSP will be expected to monitor for transport alarms associated with IP connections from the NG Emergency Services Network.

An E911SSP will also be able to detect when SS7 connectivity from the egress LSRG, or MF connectivity to the PSAP, is unavailable, resulting in SR or PSAP isolation. The E911SSP will be responsible for capturing network traffic, generating alarms and producing other metrics for monitoring and troubleshooting outages within the legacy Emergency Services Network elements and the egress LSRG.

6.2.6.2.2 Location Delivery Failures

Failures Detected by Originating Network Providers

The ability for an IP-based originating network to detect location delivery failures in an architecture where emergency calls are delivered to legacy PSAPs via SRs that are connected to NG Emergency Services Networks via egress LSRGs will be the same as described in Clause 6.2.3.2.1, with the following clarification. The originating network provider must also support location dereference requests from egress LSRGs (via Demarc Point 20). If an IP-based originating network receives a dereference request from an egress LSRG, it can conclude that the location-by-reference that it signaled to the NG Emergency Services Network was successfully delivered to the LSRG, but it will not have visibility into whether or not location is successfully delivered to the legacy PSAP. In addition, the IP-based originating network will be able to detect any failures to provide location-by-value in response to location dereference requests from LSRGs.

ATIS-0500034

The ability for a legacy originating network to detect location delivery failures in an architecture where emergency calls are delivered to legacy PSAPs by SRs that are connected to NG Emergency Services Networks via egress LSRGs will be the same as described in Clause 6.2.4.2.1, with the following clarification. An originating network provider that operates an LNG must support location dereference requests from egress LSRGs (via Demarc Point 19). If an LNG receives a dereference request from an LSRG, it can conclude that that the location-by-reference that it signaled to the NG Emergency Services Network was successfully delivered to the LSRG, but it will have no visibility into whether or not location information is successfully delivered to the legacy PSAP. The LNG will also be able to detect any failures to provide location-by-value in response to location dereference requests from LSRGs.

Failures Detected by NG9-1-1 System Service Providers

The ability for an NG911SSP to detect location delivery failures in an architecture where emergency calls are delivered to legacy PSAPs by SRs that are connected to NG Emergency Services Networks via egress LSRGs will be the same as described in Clauses 6.2.3.2.2 and 6.2.4.2.2, with the following clarifications. The NG911SSP will be able to determine whether location information received from the IP originating network or LNG ("by-value" or "by-reference") with the call is successfully delivered to the egress LSRG (i.e., via Demarc Point 18), but will not be able to determine whether location information was successfully delivered to the legacy PSAP.

Failures Detected by E9-1-1 System Service Providers

Since the E911SSP is assumed to also be responsible for operating the egress LSRG, the E911SSP will have the ability to determine whether or not location information was included in the incoming SIP signaling received by the egress LSRG from an NG Emergency Services Network (i.e., via Demarc Point 18). The E911SSP will also be able to determine whether a calling number and/or pANI (i.e., the location key generated by the egress LSRG) was received by the SR in incoming SS7 signaling from the egress LSRG, and the SR was able to successfully deliver that information to the target PSAP with the call. If the SR fails to receive a calling number/pANI in incoming signaling from the LSRG, it will include a substitute ANI string (e.g., 0-911-0000 or 000-911-0000) in the signaling to the PSAP. If an ANI failure condition is encountered by an SR, the E911SSP can also conclude that an ALI failure has occurred, since the calling number/pANI is the key to the location information for a call routed via an egress LSRG.

Since the E911SSP is also the LSRG provider, an E911SSP that is also an ALI provider will be responsible for steering location queries received by the ALI system from the PSAP to the egress LSRG. The E911SSP will be able to detect whether or not those queries result in the successful return of location information by the LSRG. An E911SSP that is also an ALI provider will also be able to detect whether that location information was successfully returned by the ALI system to the PSAP.

Since the E911SSP also has responsibility for the LSRG, it will have visibility into whether a location dereference request initiated by an egress LSRG toward an originating network (i.e., via Demarc Point 20) or toward an LNG (i.e., via Demarc Point 19) resulted in the successful return of location information to the LSRG. The E911SSP will also be able to determine whether location information was successfully delivered to the legacy PSAP via the ALI system.

6.2.6.2.3 Callback Information Delivery Failures

Failures Detected by Originating Network Providers

IP-based originating network providers will have the ability to determine whether outgoing signaling delivered to an NG Emergency Services Network (via Demarc Point 3) includes callback information, but they will not be able to detect whether the callback information was successfully delivered to an egress LSRG or PSAP.

The ability for a legacy originating network to detect failures in the delivery of callback information in an architecture where emergency calls are delivered to legacy PSAPs by SRs that are connected to NG Emergency Services Networks via egress LSRGs will be the same as described in Clause 6.2.4.3.1, with the following clarification. Legacy wireline originating network providers and legacy wireless originating network providers that use the NCAS method will be able to determine whether outgoing MF or SS7 signaling delivered to an LNG (i.e., via Demarc 1) includes an MF ANI or SS7 Calling Party Number, but they will not be able to detect whether the callback information was successfully delivered to an egress LSRG or PSAP. If the legacy originating network provider also operates the LNG, it will be able to determine whether the SIP signaling delivered to the NG Emergency Services Network (via Demarc Point 3) includes callback information, but they will not be able to detect whether the callback information was successfully delivered to an egress LSRG or PSAP.

Failures Detected by NG9-1-1 System Service Providers

NG911SSPs will be able to determine whether callback information was received in incoming signaling from an IP originating network or LNG, and will also be able to detect whether callback information was successfully delivered to an egress LSRG (i.e., via Demarc Point 18), but they will not be able to detect whether callback information was successfully delivered to the PSAP.

Failures Detected by E9-1-1 System Service Providers

Since the E911SSP is assumed to also be responsible for operating the egress LSRG, the E911SSP will have the ability to determine whether or not callback information was included in the incoming SIP signaling received by the egress LSRG from an NG Emergency Services Network (i.e., via Demarc Point 18). The E911SSP will also be able to determine whether an SS7 Calling Party Number parameter populated with callback information was delivered to the SR by the egress LSRG, as well as whether the SR was able to successfully deliver that callback information to the target PSAP with the call. If the SR fails to receive an SS7 Calling Party Number containing callback information in incoming signaling from the LSRG, and the PSAP expects to receive callback information via the MF interface from the SR, the SR will include a substitute ANI string (e.g., 0-911-0000 or 000-911-0000) in the signaling to the PSAP. The E911SSP will be able to detect whether an ANI failure condition is encountered by an SR.

If the E911SSP is also the ALI provider, it will be able to detect whether callback information is included in responses to ALI queries steered by the ALI system to the egress LSRG. An E911SSP that is also an ALI provider will also be able to detect whether that callback information was successfully returned by the ALI system to the PSAP.

7 Bandwidth Sizing in Support of NG9-1-1

In an E9-1-1 environment, P.01 is the minimum recommended Grade of Service (GOS) for 9-1-1 trunk groups. P.01 is the grade of service reflecting the probability that one call out of one hundred during the average busy hour will be blocked. NENA 03-506, *E9-1-1 Voice Circuit Requirements – Providing a P.01 Grade of Service* [Ref 10], provides instructions for determining the number of trunks required in a 9-1-1 trunk group to provide a P.01 Grade of Service. The methodology described in NENA 03-506 applies between any of the following: End Office to Selective Router (SR); SR to PSAP; E9-1-1 gateway to the SR; Mobile Switching Center (MSC) to SR. NENA 03-506 utilizes Poisson Traffic Theory and the associated Poisson Trunk Requirements Table, which is found in Appendix A of NENA 03-506.

The primary factor in the Poisson Trunk Tables is known as “CCS”, or one hundred call seconds. To determine the number of circuits required to achieve P.01 Grade of Service utilizing the Poisson Trunk Tables in Appendix A of NENA 03-506, the following steps should be followed:

1. Determine the average length of time, in seconds, that a 9-1-1 call is in progress.
2. Determine the total number of 9-1-1 calls that occur during the “average busy hour”.
3. Multiply the number of average busy hour calls by the number of seconds per call.
4. Divide the value obtained in Step 3 by 100. The answer equals the number of CCS of traffic occurring during the average busy hour.
5. Consult the Trunk Table in Appendix A of NENA 03-506 under the P.01 Grade of Service to determine the number of circuits required to provide that grade of service. It is recommended that, if the CCS falls between two different trunking levels, the number of trunks be rounded up to achieve the desired Public Safety Grade of Service.

An estimate of the bandwidth required in an NG9-1-1 environment is based on the number of trunks required to achieve P.01 Grade of Service, which loosely equates to the number of “seats” at a PSAP (dependent upon the PSAPs staffing capabilities).

An Originating Service Provider (OSP) that is concerned with building interoffice transport to the ESInet ingress point so that a P.01 GOS is achieved will estimate the minimum required bandwidth by multiplying the number of E9-1-1 trunks that would have been required to achieve P.01 GOS (which is either known based on implementation or calculated as described above) by 120 Kbps.

An NG911SSP can use the same mechanism as the OSP to estimate ingress bandwidth requirements, and will also need to develop recommendations for the proper bandwidth needed between the ESInet egress point and the PSAP ingress point. This would be calculated on a “per seat” basis. While the bandwidth required between the

ESInet and the PSAP will be dependent on the type of CPE supported by the PSAP and can vary significantly between vendor implementations, in most cases a minimum of 120 Kbps per seat is recommended.

To accommodate video, much higher bandwidth may need to be supported. NENA 08-506, *NENA Emergency Services IP Network Design for NG9-1-1* [Ref 11], addresses bandwidth requirements to support video. It notes that, while best practice for PSAP design would be to support all media at all positions, it is unlikely that all positions would have to be able to support the highest level of video simultaneously. NENA 08-506 suggests one possible formula for calculating required bandwidth as 2 Mbps per PSAP + 2 Mbps per call-center position equipped for video, with more (or less) bandwidth being appropriate for a given ESInet.

It is important to note that the mechanisms described above only provide an estimate of the bandwidth required. Bandwidth requirements would need to be refined over time through practical experience.

8 Summary

The purpose of this Technical Report is to compare the service architectures used today to provide E9-1-1 with NG9-1-1 service architectures and to identify where in the architectures service-impacting events can be detected. However, it should be noted that the technical limitations outlined in this document limit any given stakeholder's monitoring and reporting capabilities. Therefore, no expectation should be made that any given stakeholder will be able to monitor and report on portions of an NG9-1-1 call path that they do not have visibility into or cannot control.

Annex A
(informative)

Annex A: Roles-to-Failure Visibility Chart

This color shading indicates the Minimum Demarcation Points for the Typical NG9-1-1 Configuration [Clause 6.2.2.14]

For details about the relationship between roles and Demarc Points, see Clause 6.

Roles	NG9-1-1 Demarcation Points ⁱ													LSRG Demarcation Points ⁱⁱ							
	1	2	3	4	5	6	7	8	9	10	11	12	13	14	15	16	17	18	19	20	
OSP-Legacy	Yes ⁱⁱⁱ	Yes																			
OSP-IP-Based			Yes		Yes			Yes					Yes								Yes
LNG Operator	Yes	Yes	Yes	Yes			Yes					Yes								Yes	
E911SSP														Yes	Yes	Yes	Yes	Yes	Yes	Yes	Yes
NG911SSP	Yes	Yes	Yes	Yes	Yes	Yes				Yes	Yes			Yes	Yes				Yes		
LPG Operator						Yes	Yes	Yes	Yes	Yes						Yes					

ⁱ Each NG9-1-1 Demarcation Point is explained in Clause 6.2.2 of the baseline.

ⁱⁱ Each LSRG Demarcation Points are explained in Clauses 6.2.6.1 and 6.2.6.2 of the baseline.

ⁱⁱⁱ The term “Yes” indicates that the Demarcation Point is most likely visible to the associated Role for monitoring and reporting purposes.